

Spring Cable Reels

Program 6100



CONDUCTIX
wampfler
DELACHAUX GROUP

Contents

Spring Cable Reels General Information

General Information	5
Technical Characteristics	5
Applicable International Regulations	5
Conductix-Wampfler Spring Cable Reels	6

Cable Selection

General	7
Different Types of Cable	7
Reeling Cable PUR(NSHTÖU)	7
Performance and Price of Different Cables	7
Which cables are to be used?	8
Current Carrying Capacity	8
Calculation of the Current Loads of AC and DC Motors	8
De-Rating Factors	9
Example	9

Cables

Cables Cordaflex(SMK) (N)SHTÖU-J	10
Cables NSHTÖU-J	10
Special Cables PUR(NSHTÖU)	11
Cables FLGÖU-J (MTGÖU-J)	11
Special Cables PUR	12

Mechanical Criteria

Spring Drive	12
Minimum Permissible Bending Radius	13
Roller Guide Arrangement	13
Maximum Permissible Cable Tension	13

Selection Tables for Reels

Hints on Using the Cable Reel Selection Tables	14
Application 1 and 3: Horizontal and Vertical Retrieval	14
Application 4: Vertical Lift (Drum on Top)	24

Springs and Slip Ring Assemblies

Spring Motors and Spring Forces	33
Slip Ring Assemblies	33

Springs and Slip Ring Assemblies

Spring Cable Reels BEF150	34
Spring Cable Reels BEF 180 to 500	35

Accessories

Cable Grips	36
Cable Collars	36
Deflection Pulley	36
Rubber End Stops	37
Support Rollers, Roller Nozzles	37
Easy Mounting Roller Guides Open	38
Terminal Box Mounting Flange	38
Mounting Stands	39
Heaters Units	39
Limit Switches	39
Locking Devices	40
Guide Arms	40
Swivelling Consoles	41

Questionnaire

Spring Cable Reels Questionnaire	42
--	----



DS 508

Spring Cable Reels General Information

General

Spring cable reels are used for the automatic reeling of cables on various types of moving equipment. These include most hoisting and other material handling devices; e.g. portal cranes, grabs, magnets, lift and working platforms, machinery, excavators, mobile cranes, transfer cars, transport systems and skimmers in purifying plants.

Mostly these machines are track-based and operate in a straight line. The orientation of these applications for the transfer of electric power and control signals by reeling can be horizontal or vertical. In addition to the cables listed in this catalog, others can be offered for special demands and requirements.

In addition to the reels presented in this catalog, we can supply:

- Hose reels for liquids and gases
- Reels for machines of non-linear movement (reels with rotation of 360° or more)
- Monospiral reels
- Reels for corrosive ambient conditions
- Other special applications

The BEF 6100 type spring cable reels are in accordance with all relevant quality and safety standards.

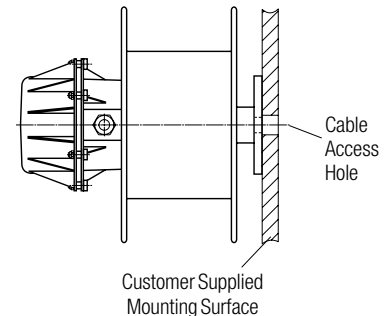

Technical Characteristics

A BEF type spring cable reel consists of the following components:

- Cable drum
- Spring motor
- Slip ring assembly
- Mounting flange
- Various optional accessories

Cable Drum:

The cable drum is based on a heavy gauge sheet metal design. The drum body is epoxy coated for corrosion protection and the flanges are galvanised. The flanges are bolted to the drum body and the inside is exclusively used for the springs. It is mounted on both sides with lifetime lubricated ball bearings.

Spring Motor:

The spring motor consists of individually encapsulated springs made of special spring steel. This guarantees long service-life (approx. 100,000 movements or 50,000 stress cycles). The fully encapsulated springs provide a safe handling and replacement.

Slip Ring Assembly:

The slip ring is needed to transfer electric power and control signals from the fixed supply to the rotating reel. The reference voltage and the operating voltage are 415 VAC to 660 VAC, respectively; and the current carrying capacity ranges from 50 mA to 150 A nominal at +30° C. Multi-layer coated slip rings in combination with silver collector shoes for data transmission are available upon request.

Slip ring assemblies are designed for insulation group C and are all rated at 100% duty cycle.

The slip ring housing made of impact-resistant plastic has a dust and moisture protection grade of IP65.

Slip ring types 16 and 19, in galvanized sheet metal housing, have a dust and moisture protection grade of IP55.

Mounting Flange:

Cable reels are supplied with easy installation mounting flange. Special requirements or modified adaptations such as backstops, fixed or swivel guide arms with cable roller guides are available.

Accessories:

Mounting stand, swivel mounts, space heater, ratchets, limit switches, etc. are available.

Regulations

All cable reels are delivered in standard unwinding-direction (left), as shown on the slip ring assembly housing unwinding counter-clockwise. All reels listed are calculated in accordance to the permissible cable tension and minimum bending radius stated by the cable manufacturers. Some cable manufacturers offer cables for higher tensions and smaller radii. This may make more economic reel solutions possible. On request we will calculate cable reels using this opportunity. The reeling will be random winding. For tension relief purposes when the reel is completely unwound there must be two additional cable windings remaining on the reel.

Conductix-Wampfler Spring Cable Reels

Conductix-Wampfler Spring Cable Reels

A wide range of reels with versatile accessories for many varied applications:

- The reel bodies have inner diameters ranging from 150 to 500 mm for cables from 1 to 35 mm²
- Travel speeds up to 63 m/min and accelerations up to 0.3 m/sec² for horizontal and vertical lift applications
- Dust and moisture protection IP 65 as standard (IP 55 on slip ring assembly Type 16 and 19)
- Special slip rings for communication and data transmission available
- For your convenience, spring cable reels can be supplied with cable pre-wired to slip ring
- Many versatile accessories
- Advanced design
- Simple installation
- Simple to set-up
- Patented spring safety cassette
- Safe spring replacement
- Long spring life
- Maintenance friendly
- High grade corrosion protection
- Economical



Spool

- Optimum reeling performance for the cable
- Lifetime lubricated bearings
- Compact, flange-mounted reels with variable adaption possibilities for easy installation
- High degree of corrosion protection - all metal sheet and plate parts are galvanized or powder coated

Encapsulated Safety Springs

- Special long life springs are encapsulated into an easy to handle patented safety cassette
- Easy and safe change of reeling direction possible
- Replacement of springs is safe and easy
- Springs will not be damaged by turning the reel in the wrong direction

Slip Ring Assembly

- Standard slip ring assembly housings are made of impact-resistant plastic to prevent condensation, IP65
- Cable connection through a side-mounted cable gland
- Easy connection of the conductors and simple replacement of the current collectors



Cable Selection

General

Cables most commonly associated with reeling applications are normally available from stock and can be supplied immediately. Most spring cable reels can be provided with reeled up and connected cable.

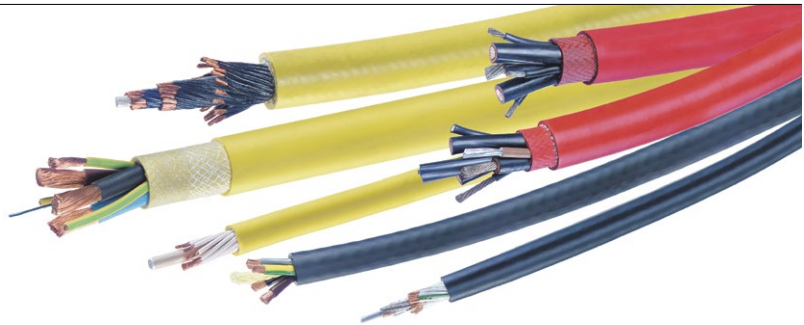

Different Types of Cable

Neoprene, flexible, non-reeling cable without tension relief

A typical cable of this type is the H07RN-F, which is offered by some reel manufacturers. Conductix-Wampfler offers this cable with some restrictions.

Neoprene, flexible restricted reeling cable with tension relief

Cables of this type are the FLGÖU-J (MTGÖU-J). These can be used for simple applications without frequent and strong loads. The advantages of this cable are the small diameter and the low weight. This will allow for a small and cost-effective reel. The cable itself is also cost-effective.

Neoprene, flexible reeling cable with tension relief

These are cables with the designation NSHTÖU, which are characterised as being good quality at a medium price. Cordaflex (SMK) cables are also available, which are also suitable for special loads. The advantages are the small diameter and the low weight of these cables.

Polyurethane cables

These include PUR and PUR(NSHTÖU) cables with Polyurethane outer material. This material allows a low wall thickness and consequently a smaller diameter and weight of the cables. The PUR (NSHTÖU) cable has better properties than the standard NSHTÖU, but is more expensive.

Reeling Cable PUR(NSHTÖU) for Reels

The reeling cable PUR (NSHTÖU) combines the approved characteristics of the NSHTÖU with the benefits of the sheathing material Polyurethane. The PUR material and the improved construction are responsible for better tension relief values and mechanical properties.

This cable is therefore recommended for high and extraordinary mechanical load. The thermal load capacity will also allow applications at a temperature range of -40° C to +80° C.

Moreover this cable has optimum values with regard to weight and dimensions. This means, the reels and their drives can have smaller dimensions, which will also reduce costs.

Another advantage of the PUR(NSHTÖU) cable is halogen-free composition, which helps to meet the ever increasing requirements.

Performance and Price of different Cables

Cable Type	Spring Reel Load		Motor Reel Load			Price
	low	high	low	high	extreme	
FLGÖU-J (MTGÖU-J)	++	0	-	-	-	low
PUR ¹⁾	++	0	+	0	-	low
PUR(NSHTÖU)	+	++	+	++	++	high
NSHTÖU	+	++	++	+	0	medium
Cordaflex (SMK) (N)SHTÖU-J	+	++	+	+	++	high

++ main application + suitable 0 with restrictions - not suitable

1) reeling only possible with restrictions according to VDE

Load low	Load high	Load extreme
<ul style="list-style-type: none"> • Pull-off horizontally • Speed up to 60 m/min • Without deflection 	<ul style="list-style-type: none"> • Pull-off horizontally and vertically • Speed up to 100 m/min • With deflection 	<ul style="list-style-type: none"> • Pull-off horizontally and vertically • Speed up to 180 m/min • With several deflections

Cable Selection

Which cables are to be used?

Based on the VDE standards and the latest technology the following cables are applicable in accordance with the mode of operation and the consumer:

- as reeling cable: Cordaflex(SMK) (N)SHTÖU-J; NSHTÖU-J; PUR(NSHTÖU)
- of limited reeling cable: Neoprene cable with support element FLGÖU-J (MTGÖU-J); PUR

For the proper selection of cables the operating conditions must be stated. For the selection of the correct cable cross-section it is required to consider the current load and the voltage drop over the total cable length.

Current Carrying Capacity

The current load of a drive often determines the cross-section for the main power supply. A corresponding calculation for control cables is unnecessary in most cases.

Table 1 – Guide Values of Current Load on AC Motors at Full Power for the Most Common Voltages

Motor Capacity [kW]	Efficiency [η]	Power factor [cos φ]	Nominal Voltage							
			230 V		400 V		500 V		690 V	
			I [A]	A [mm²]	I [A]	A [mm²]	I [A]	A [mm²]	I [A]	A [mm²]
0.37	0.66	0.7	2		1.1		0.9		0.7	
0.55	0.69	0.7	2.7		1.5		1.2		0.9	
0.75	0.74	0.7	3.2		1.9		1.5		1.1	
1.1	0.74	0.81	4.6	1.5 ¹⁾	2.6		2.1		1.5	
1.5	0.74	0.81	6.3		3.6	1.5 ¹⁾	2.9	1.5 ¹⁾	2.1	1.5 ¹⁾
2.2	0.78	0.81	8.7		5		4		2.9	
3.0	0.80	0.81	11.5		6.5		5.3		3.8	
4.0	0.83	0.82	14.8	1.5	8.5		6.8		4.9	
5.5	0.86	0.82	19.6	2.5	11.3		9		6.5	
7.5	0.87	0.82	26.4	4	15.2	2.5	12.1	1.5	8.8	
11	0.87	0.82	38	10	21.7	4	17.4	2.5	12.6	1.5
15	0.88	0.84	51		29.3	6	23.4	4	17	2.5
18.5	0.88	0.84	63	16	36		28.9		20.9	
22	0.92	0.84	71	25	41	10	33	6	23.8	4
30	0.92	0.84	96	35	55	16	44	10	32	6

1) Preferred cross-section (lower cross-sections are also possible in theory)

These values are guide values for a duty ratio of 100% at an ambient temperature of 30° C. They consider 3 loaded cores on a monospiral winding. Other operating conditions have to be calculated by means of the following tables.

Calculation of the Current Loads of AC and DC Motors

Alternating Current

$$I = \frac{P \times 1000}{\sqrt{3} \times U \times \cos\phi}$$

Direct Current

$$I = \frac{P \times 1000}{U \times \eta}$$

I = Current in A • U = Voltage in V • P = motor power in kW

$$\cos\phi = \text{power factor} = \frac{\text{true power}}{\text{apparent power}}$$

$$\eta = \text{efficiency} = \frac{\text{power out}}{\text{power in}}$$

When calculating the necessary cross-section, the operating conditions must be considered in any case. They are considered with the help of the de-rating factors stated in VDE0298 part 4. The necessary cross-section must be determined in accordance to table 2, in consideration of the maximum permanent load after revision of the maximum permissible current. For the operation of the reel the self-heating of the reel

cable is the most important factor. It must always be within the operating limits of the cable used. The table contains values for the current carrying capacity I_z of insulated cables with copper cross-sections and of cables that are not laid underground for flexible energy supply systems at ambient temperatures of +30° C.

Table 2 - Current Carrying Capacity of Flexible Cables with Nominal Currents up to 1000 V

Max. Permanent Load	[A]	15	18	26	34	44	61	82	108	135	168	207	250	292	60° C allowed Ambient Conductor Temperature
Cross-Section	[mm²]	1	1.5	2.5	4	6	10	16	25	35	50	70	95	120	

In accordance with VDE 0298 Part 4 (table 9, column 5)

Cable Selection

De-Rating Factors

The following tables contain de-rating factors for current carrying capacity of cables:

- De-rating factor for intermittent operation (Table 3)
- De-rating factors for variation from ambient temperature (Table 4)
- De-rating factors for multi-conductor cable with conductor cross sections up to 10 mm² (Table 5)
- De-rating for multi-layers of cable (Table 6)

Cross-section [mm ²]	Duty Cycle [%]			
	60	40	25	15
1.0	1.00	1.00	1.00	1.00
1.5	1.00	1.00	1.00	1.00
2.5	1.00	1.00	1.04	1.07
4.0	1.00	1.03	1.05	1.19
6.0	1.00	1.04	1.13	1.27
10.0	1.03	1.09	1.21	1.44
16	1.07	1.16	1.34	1.62
25	1.10	1.23	1.46	1.79
35	1.13	1.28	1.53	1.90

The values are for continuous operation (100% duty cycle). The above stated de-rating factors can be used for the calculation of the current carrying capacity.

- Ambient temperature +30° C
- Maximum cycle duration 10 min

Permissible Operation Temperature In °C	60° C	70° C	80° C	90° C
	De-Rating Factor			
Ambient Temperature In °C				
10	1.29	1.22	1.18	1.15
15	1.22	1.17	1.14	1.12
20	1.15	1.12	1.10	1.08
25	1.08	1.06	1.05	1.04
30	1.00	1.00	1.00	1.00
35	0.91	0.94	0.95	0.96
40	0.82	0.87	0.89	0.91
45	0.71	0.79	0.84	0.87
50	0.58	0.71	0.77	0.82
55	0.41	0.61	0.71	0.76
60	-	0.50	0.63	0.71
70	-	-	0.45	0.58
80	-	-	-	0.41

In accordance with VDE 0298 Part 4 (table 15)

Number Of Conductors	De-Rating-Factor
5	0.75
7	0.65
10	0.55
14	0.50
19	0.45
24	0.40
40	0.30

In accordance with VDE 0298 Part 4 (table 20)

No. Of Layers Lz	De-Rating-Factor
1	0.80
2	0.61
3	0.49
4	0.40

In accordance with VDE 0298 Part 4 (table 21)

Example

Power is supplied to the motor through a cable reel, both of which are mounted onto a moving transfer car. A 35 m length of cable is required to supply 2.2 kW of power to the motor. The following data is known:

- P = 2.2 kW
- U = 380 VAC
- Power factor, cosφ = 0.89
- Efficiency, η = 0.8
- Ambient temperature = +50° C
- Resultant operating temperature of cable = +60° C
- 7-Core cable (5 cores in operation)
- 60% Duty cycle

Resulting Current Load:

$$I = \frac{P \times 1000}{\sqrt{3} \times U \times \cos\phi}$$

$$I = \frac{2,2 \times 1000}{\sqrt{3} \times 380 \times 0.89 \times 0.8} \quad | \quad I = 4.7 \text{ A}$$

Correction

An increased cable cross-section is necessary because of the operating conditions and the size of the reel.

De-Rating Factors:

- De-rating factor for 60% duty cycle operation, from Table 3 $f_{ED} = 1.0$
- De-rating factor for variation from ambient temperature, from Table 4 (operating temperature +60° C) $f_T = 0.58$
- De-rating factor for multi-conductor cable, Table 5 (number of cores in operation) $f_{Ad} = 0.75$
- De-rating factor for multi-layers of cable, Table 6 (3 layers) $f_{Lz} = 0.49$

Calculation of the Necessary Cable Cross-Section:

$$I_k = \frac{I}{f_{ED} \times f_T \times f_{Ad} \times f_{Lz}}$$

$$I_k = \frac{4,7}{1.0 \times 0.58 \times 0.75 \times 0.49} \quad | \quad I_k = 22 \text{ A}$$

Resulting Cable Cross-Section (From Table 2):
2.5 mm² (max 26 A)

Cables

Cables Cordaflex(SMK) (N)SHTÖU-J

Cross-Section	Order No.	Delivery Time	dI [mm]	qI [kg/m]	Cu-Weight [kg/km]
4 x 1.5	2158791	2	13	0.24	60
5 x 1.5	1158792	2	13.8	0.28	75
7 x 1.5	2158793	2	16.2	0.38	106
12 x 1.5	1158794	2	22.4	0.71	182
18 x 1.5	2158795	2	22.3	0.76	272
24 x 1.5	1158797	2	25.3	0.99	363
30 x 1.5	2158797	OR	28.1	1.22	454
36 x 1.5	3007794	OR	28	1.26	543
4 x 2.5	2158805	2	14	0.3	101
5 x 2.5	2158806	2	15	0.35	126
7 x 2.5	1158807	2	17.6	0.51	176
12 x 2.5	1158808	2	24.4	0.92	302
18 x 2.5	1158809	2	24.3	1.05	454
24 x 2.5	1158810	2	27.7	1.32	605
19 x 2.5 + 5 x 1 (C)	2158823	2	27.7	1.29	585
3 x 35 + 3 x 16/3	2158834	2	30	2.16	1217
4 x 4	2158825	2	17	0.45	161
4 x 6	2158826	2	18.4	0.57	242
4 x 10	2158827	2	22.6	0.9	424
4 x 16	2158828	2	25.2	1.24	645
4 x 25	2158829	2	30	1.85	1068
5 x 4	3007796	2	18.4	0.43	201
5 x 6	2158831	2	20	0.69	302
5 x 10	2158832	2	24.4	1.08	503
5 x 16	2158833	2	27.6	1.5	805

Delivery Time: S = Ex-Stock; 2 = 2 Weeks; OR = On Request

Cables NSHTÖU-J

Cross-Section	Order No.	Delivery Time	dI [mm]	qI [kg/m]	Cu-Weight [kg/km]
4 x 1.5	1037434	S	13.5	0.24	58
5 x 1.5	1037436	S	14.6	0.28	72
7 x 1.5	1037437	S	18	0.45	101
12 x 1.5	1037438	S	21	0.65	173
18 x 1.5	1037439	S	24.3	0.87	259
24 x 1.5	1037440	S	28	1.12	346
30 x 1.5	1037441	S	30	1.32	432
4 x 2.5	1037443	S	16.2	0.35	96
5 x 2.5	1037444	S	17.4	0.41	120
7 x 2.5	1037445	S	20.2	0.6	168
8 x 2.5	1146968	2	23	0.7	192
12 x 2.5	1037446	S	23.8	0.86	288
18 x 2.5	1037447	S	28.7	1.24	432
4 x 4	1037451	S	19.1	0.49	154
5 x 4	1037452	S	21.5	0.64	192
4 x 6	1037454	S	20.7	0.61	230
5 x 6	1040625	2	21.8	0.75	317
4 x 10	1037455	S	25	0.94	384
5 x 10	1043882	2	30.5	1.23	528
4 x 16	1037456	S	29	1.32	614
5 x 16	1037458	2	34.5	1.63	844

Delivery Time: S = Ex-Stock; 2 = 2 Weeks; OR = On Request

- Design: to DIN/VDE0250, Part 814
- Nominal voltage: U₀/U = 600/1000V
- Test voltage: 2500 V
- Permissible operating temperature on the conductor: +90° C
- Ambient temperature range: -35° C to +50° C
- Continuous tension force: 15 N/mm² to DIN/VDE 0298, Part 3 (20 N/mm² per supplier)
- Minimum bending radius: to DIN/VDE 0298, Part 3

Specially designed reeling cable for hoists and other mechanically demanding material handling applications for outdoor use in dry, humid and wet environments.

Sample applications are electro-hydraulic grabs, hoist magnets, cranes, etc.

- Design: to DIN/VDE0250, Part 814
- Nominal voltage: 1000 V
- Test voltage: 2500 V
- Permissible operating temperature on the conductor: +90° C
- Ambient temperature range: -35° C to +50° C
- Continuous tension force: 15 N/mm² to DIN/VDE 0298, Part 3 (25 N/mm² per supplier)
- Minimum bending radius: to DIN/VDE 0298, Part 3

Specially designed reeling cable for hoists and other mechanically demanding material handling applications for outdoor use in dry, humid and wet environments.

Sample applications are electro-hydraulic grabs, hoist magnets, cranes, etc.

Cables

Special Cables PUR(NSHTÖU)

Cross-Section	Order No.	Delivery Time	dI [mm]	qI [kg/m]	Cu-Weight [kg/km]
4 x 1.5	1157365	2	10.5	0.15	58
5 x 1.5	1157366	2	11.2	0.18	81
7 x 1.5	1157367	S	12.6	0.23	115
12 x 1.5	1157368	S	16.1	0.36	196
18 x 1.5	1157369	S	17	0.47	271
24 x 1.5	1157370	2	21.5	0.59	392
30 x 1.5	1157371	2	23	0.71	450
4 x 2.5	1157375	S	11.5	0.21	99
5 x 2.5	1157376	S	12.2	0.24	125
7 x 2.5	1157377	S	13.3	0.31	180
12 x 2.5	1157378	S	19.9	0.48	308
18 x 2.5	1157379	S	19.5	0.68	451
24 x 2.5	1157380	S	24.3	0.82	616
30 x 2.5	1157381	2	27.3	0.97	771
19 x 2.5 + 5 x 1 (C)	1160149	2	24.3	0.82	635
4 x 4	1157382	2	12.7	0.28	160
4 x 6	1157384	2	14	0.37	241
4 x 10	1157386	S	17.9	0.61	404
4 x 16	1157388	2	22.3	0.92	645
4 x 25	1157390	2	25.8	1.27	1005
4 x 35	2157391	2	28.3	1.72	1417
5 x 4	1157383	2	13.8	0.32	200
5 x 6	1157385	S	15.3	0.43	317
5 x 16	3005099	2	24.3	1.07	844

Delivery Time: S = Ex-Stock; 2 = 2 Weeks; OR = On Request

Cables FLGÖU-J (MTGÖU-J)

Cross-Section	Order No.	Delivery Time	dI [mm]	qI [kg/m]	Cu-Weight [kg/km]
3 x 1.0	1037404	2	9.5	0.12	31
7 x 1.0	1037408	S	14	0.24	67
9 x 1.0	1037409	OR	14	0.27	91
12 x 1.0	1037410	2	15.9	0.4	115
16 x 1.0	1037411	2	16.4	0.44	154
18 x 1.0	1037412	2	17.3	0.49	173
24 x 1.0	1037413	2	20.6	0.66	230
36 x 1.0	1037414	2	24.3	0.96	346
3 x 1.5	1037415	2	10	0.14	46
4 x 1.5	1037416	2	11	0.22	58
5 x 1.5	1037417	S	12	0.23	72
7 x 1.5	1037418	S	13	0.28	101
8 x 1.5	1037419	2	14	0.32	115
9 x 1.5	1037420	2	15	0.35	130
12 x 1.5	1037421	S	19	0.52	173
18 x 1.5	1037422	S	21	0.64	259
24 x 1.5	1037423	S	23	0.84	346
4 x 2.5	1037424	S	13	0.32	96
7 x 2.5	1037426	2	15	0.39	168
12 x 2.5	1037427	2	22	0.72	288
18 x 2.5	1037429	OR	25	0.9	432
24 x 2.5	1037433	2	27	1.22	576

Delivery Time: S = Ex-Stock; 2 = 2 Weeks; OR = On Request

- Conductor design: finely stranded flexible copper according to DIN VDE 0295 Class 5
- Sheath: Polyurethan, matt black, flame-retardant
- Nominal voltage: U0/U = 600/1000 V
- Permissible operating temperature on the conductor: +80° C
- Continuous tension force: up to 25 mm² - 25 N/mm², 35 mm² and larger - 20 N/mm²
- Minimum bending radius: to DIN/VDE 0298, Part 3

Specially designed reeling cable for hoists and other mechanically demanding material handling applications for outdoor use in dry, humid and wet environments.

Sample applications are electro-hydraulic grabs, hoist magnets, cranes, etc.

- Conductor design: finely stranded flexible copper in neoprene (Chloroprene-Rubber)
- Integral support design: Hemp or sisal cord
- Sheath: neoprene (Chloroprene-Rubber); abrasion and oil resistant, flame retardant, flexible at low temperatures, black color
- Nominal voltage: 500 V
- Test voltage: 3000 V
- Permissible operating temperature on the conductor: +60° C
- Ambient temperature range: -25° C to +60° C
- Continuous tension force: 15 N/mm² to DIN/VDE 0298, Part 3
- Minimum bending radius: to DIN/VDE 0298, Part 3

Limited reel cable. For light to medium applications with a limited number of movements.

For outdoor use in dry, humid and wet environments.

Cables / Mechanical Criteria

Special Cables PUR

Cross-Section	Order No.	Delivery Time	dI [mm]	qI [kg/m]	Cu-Weight [kg/km]
4 x 2.5	1150410	S	9	0.18	92
12 x 2.5	1150408	2	18	0.58	276
18 x 2.5	1150409	S	18	0.64	432
36 x 2.5	1150529	2	25	1.3	828
26 x 2.5 + 4 x 2.5 (C)	171837	S	24.5	1.22	675
4 x 4	1150411	2	11.5	0.23	148
4 x 6	1150412	S	13	0.32	221
4 x 10	1150413	S	15.5	0.5	368
4 x 16	1150414	S	19	0.8	588
3 x 25 + 3G6	1150796	2	21.5	1.04	837
3 x 35 + 3G6	1150540	2	25	1.41	1132
3 x 25 + 3G6	150796	2	26	1.26	837
3 x 35 + 3G6	150540	2	29	1.68	1132
3 x 50 + 3G10	151848	2	33	2.35	1658
3 x 70 + 3G16	-	2	39	3.4	2373

Delivery Time: S = Ex-Stock; 2 = 2 Weeks; OR = On Request

- Conductor design: flexible copper-litz according to IEC228 Class 5; Insulation made of Polyethylene
- Sheath: high quality polyurethane (PUR) per HD22-10 S1 or VDE 02 82 Class 10; abrasion and oil resistant, yellow color
- Nominal voltage: U0/U = 600/1000 V
- Permissible operating temperature on the conductor: +85° C
- Ambient temperature range: -30° C to +60° C
- Continuous tension force: 20 N/mm²
- Minimum bending radius: to DIN/VDE 0298, Part 3

Specially designed reeling cable for hoists and other mechanically demanding material handling applications for outdoor use in dry, humid and wet environments.

Sample applications are electro-hydraulic grabs, hoist magnets, cranes, etc.

Spring Drive

The diagram below illustrates the characteristics of the spring motors used. The torque during unwinding of the cable (spring is tensioned) is higher than during winding. The maximum cable tension is constant when the cable is fully unwound. This factor is significant when considering the cable to be used.

The diagram shows schematically what happens to the spring motors during the reeling operation. When the cable is being unwound, the spring resistance acts as shown in the top curve. The spring tension starts at **Z_a** and reaches its maximum at **Z**. This is the maximum force that acts on the cable when the reel is fully unwound and the springs are fully wound.

When the cable is being wound onto the reel, the resulting forces behave as depicted on the bottom curve. It should be considered to determine whether the spring force is sufficient for the operation given the selected cable.

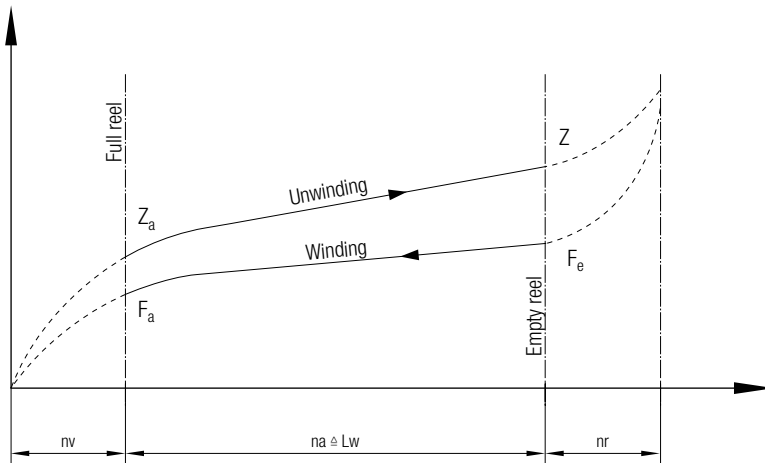

- Lw:** Maximum operational winding length of cable [m]
- na:** Maximum number working turns of the spring motor
- nv:** Required number of pre-turns for pre-loading of the spring motor
- Fa:** Remaining spring motor force if cable is fully wound-up (during winding)
- nr:** Number of remaining reserve turns when max. winding length of cable is achieved
- Fe:** Retarding spring motor force if cable is fully unwound (during unwinding)
- Za:** Required force if cable is fully wound-up (during unwinding)
- Z:** Required spring motor force if cable is fully unwound (during unwinding).

Mechanical Criteria

Minimum Permissible Bending Radius

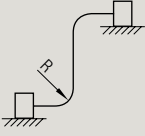
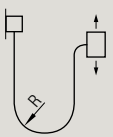
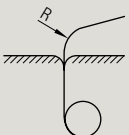
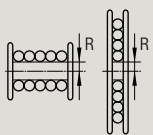
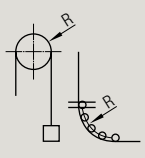
Nominal Voltage (U ₀ /U)	Max. OD of Round Cable or Thickness of Flat Cable [mm]	≤ 0.6 / 1 kV				> 0.6 / 1 kV
		≤ 8	> 8 ≤ 12	> 12 ≤ 20	> 20	
						
	Hard Wiring	3 x d	3 x d	4 x d	4 x d	6 x d
						
	Free Movement Looping	3 x d	4 x d	5 x d	5 x d	10 x d
						
	At Centre Feed	3 x d	3 x d	5 x d	5 x d	10 x d
						
	Cable Reels	5 x d	5 x d	5 x d	5 x d	12 x d
						
	Roller Guides and Sheaves	7.5 x d	7.5 x d	7.5 x d	7.5 x d	15 x d

(in accordance to DIN/VDE 0298 part 3)

Roller Guide Arrangement

Recommendations for proper roller guide or sheave roller location.

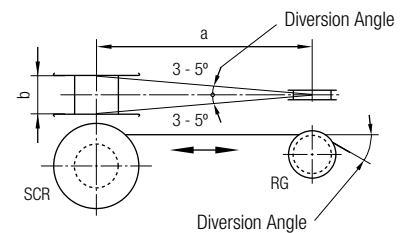

b [mm]	a [mm]	
	3° Diversion Angle	5° Diversion Angle
45	450	250
75	750	450
100	1000	600
130	1250	750
150	1450	850
220	2100	1250
250	2400	1450
320	3050	1850
380	3650	2200

Applications for roller guides with a deviation angle > 5°:

- Cables up to 20 mm
Reel diameter = 10 x cable OD
(to DIN/VDE 0298 part 3)
- Cables > 20 mm
Reel diameter = 12 x cable OD
(to DIN/VDE 0298 part 3)
- Cable independent
Roller or sheave diameter = 15 x cable OD
(to DIN/VDE 0298 part 3)

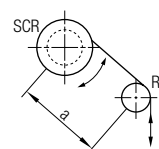
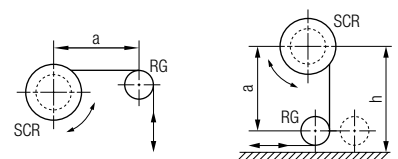
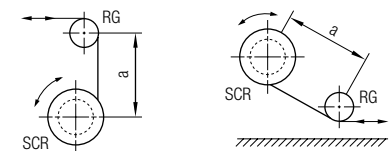

When roller guides or sheave rollers are used, the reel spring force must be checked.

Maximum Permissible Cable Tension

In accordance to VDE 0298 (Part 3) a continuous tension of 15 N/mm² on the cable is permissible for moving equipment based upon the total copper cross-section of the cable. Depending on the type of cable this value could be higher. Supplier should be consulted.

Cable screens, concentric conductors, divided conductors, additional control cores and/or supervising cores must be taken into consideration.

Selection Tables for Reels

Hints on Using the Cable Reel Selection Tables

The cable reel selection tables contain the most common applications 1 and 3 (horizontal and vertical retrieve) and 4 (vertical lift). The maximum acceleration when the cable is unwinding is 0.3 m/sec² and the maximum speed is 63 m/min. We must be consulted about all other applications. The tables contain the most common cables, provide information on the reels to be used, the spring mechanism and slip-ring assemblies based upon the required winding length.

Selection Procedure:

- Determine the number of cores, cross section and type of cable
- Establish application type and the winding length while observing installation hints.
- Go to appropriate application table
 - Look for required cable type. If you use a different cable, check diameter and weight if there are serious discrepancies.
 - Now (determine winding length and) look for the next longer winding length in the table (and determine the required total length of cable to also take into account the pre-turns of the reel).
- Read off the spring cable reel, slip ring assembly and spring motor from the table.
 - Spring motor pre-turns, spring motor working turns and the maximum cable tension Fz are noted
- Re-check the voltage and current rating of the slip ring page 33.
- Determine the part number designation as follows

Cable Reel Typ BEF

Standard Model

BEF264622 - 0405 - 2EL(T)H / R / 1 L / H / E

Options

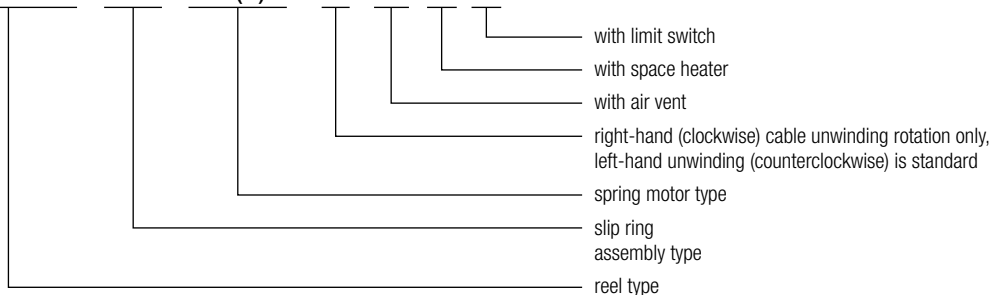

Application 1 and 3: Horizontal and Vertical Retrieval

Application 1

Horizontal Retrieval
(Reel is mounted to moving equipment),
Installation height $h \leq 1.0$ m

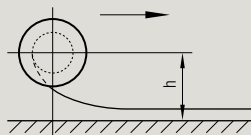

Application 3

Vertical Retrieval
(Cable is unwound vertically upward, reel is on bottom)



Maximum Unwinding Speed: $v_{\max} = 63$ m/min;
Maximum Acceleration: $a_{\max} = 0.3$ m/sec²

Z x A [mm ²]	Cables Type	ø [mm]	m [kg/m]	Cable Length		Spring Cable Reel Spool - Slip Ring Assembly - Springs	Spring Motor		
				Lw [m]	Lz		nv	na	Fz [N]
7 x 1.0	FLGÖU-J (MTGÖU-J)	14	0.24	8	2.6	BEF152809-4507-1QB	3	15	49
				17	3.0	BEF152815-4507-2QBH	6	30	49
				30	2.7	BEF224320-4507-3EH(T)H	9	39	91
				42	3.0	BEF264622-0407-3EL(T)H	9	51	73
				57	3.9	BEF264622-0407-4EL(T)H	12	68	72
				68	3.7	BEF325524-0407-3DI(T)H	12	60	100
12 x 1.0	FLGÖU-J (MTGÖU-J)	15.9	0.4	9	1.6	BEF183616-4512-2EI(T)H	4	16	95
				18	2.0	BEF224320-4512-2EH(T)H	6	26	87
				29	3.0	BEF224320-4512-3EH(T)H	9	39	87
				39	3.2	BEF264622-0412-3DH(T)H	12	41	126
				51	3.9	BEF264622-0412-4DH(T)H	16	54	123
				66	4.0	BEF325524-0412-3DI(T)H	12	60	97
18 x 1.0	FLGÖU-J (MTGÖU-J)	17.3	0.49	8	1.5	BEF183616-4518-2EI(T)H	4	16	89
				19	2.3	BEF224320-4518-2EH(T)H	6	26	88
				28	3.1	BEF224320-4518-3IC(T)H	9	33	107
				41	2.8	BEF325524-0418-2DI(T)H	8	40	95
				58	3.8	BEF325524-0418-3DI(T)H	17	55	95
				68	2.8	BEF406532-0418-3CC(T)H	9	54	150

Z = no. of conductors nv = required turns for spring preload Lw = winding length Fz = max. cable tension A = Cross-section na = max. working turns Lz = cable layers

Selection Tables for Reels

Application 1 and 3: Horizontal and Vertical Retrieval

Z x A [mm ²]	Cables Type	ø [mm]	m [kg/m]	Cable Length		Spring Cable Reel Spool - Slip Ring Assembly - Springs	Spring Motor		
				Lw [m]	Lz		nv	na	Fz [N]
24 x 1.0	FLGÖU-J (MTGÖU-J)	20.6	0.66	11	1.4	BEF264622-1824-1DH(T)	4	14	119
				23	2.5	BEF264622-1824-2DH(T)H	8	27	117
				37	3.0	BEF325524-1824-2DI(T)H	15	33	98
				51	3.1	BEF406525-1824-2CC(T)H	6	36	157
				67	3.2	BEF406532-1824-3CC(T)H	10	53	147
36 x 1.0	FLGÖU-J (MTGÖU-J)	24.3	0.96	9	1.1	BEF325524-1836-1DI(T)	12	12	91
				21	2.2	BEF325524-1836-2DI(T)	4	20	187
				33	2.5	BEF406525-1836-2CC(T)H	11	31	137
				48	2.7	BEF406532-1836-3CC(T)H	21	42	142
				63	2.8	BEF508032-1836-2BD(T)H	16	42	188
3 x 1.5	FLGÖU-J (MTGÖU-J)	10	0.14	8	1.9	BEF152109-4503-1QB	3	15	52
				16	3.3	BEF152809-4503-2QBH	6	30	50
				21	3.0	BEF152813-4503-3QBH	9	45	48
				32	1.7	BEF264622-0403-3EL(T)H	9	51	67
4 x 1.5	FLGÖU-J (MTGÖU-J)	11	0.22	11	2.7	BEF152809-4504-2QBH	6	30	43
				16	2.7	BEF152813-4504-2QBH	6	30	50
				22	1.7	BEF224320-4504-3EH(T)H	9	39	84
				30	1.8	BEF264622-0404-2EL(T)H	6	34	81
				46	2.6	BEF264622-0404-3EL(T)H	9	51	80
4 x 1.5	NSHTÖU-J	13.5	0.24	9	2.8	BEF152809-4504-1QB	3	15	51
				18	2.9	BEF152815-4504-2QBH	6	30	51
				20	1.9	BEF224320-4504-2EH(T)H	6	26	93
				31	2.2	BEF264622-0404-2EL(T)H	6	34	80
				44	3.0	BEF264622-0404-3EL(T)H	9	51	76
				70	3.6	BEF325524-0404-3DI(T)H	12	60	102
4 x 1.5	(SMK) (N)SHTÖU-J	13	0.24	10	2.7	BEF152809-4504-2QBH	6	30	41
				16	2.9	BEF152813-4504-2QBH	6	30	49
				21	1.9	BEF224320-4504-3IC(T)H	9	33	100
				31	2.7	BEF224320-4504-3EH(T)H	9	39	94
				44	3.0	BEF264622-0404-3EL(T)H	9	51	76
				70	3.4	BEF325524-0404-4DI(T)H	16	80	91
4 x 1.5	PUR(NSHTÖU)	10.5	0.15	8	2.1	BEF152809-4504-1QB	3	15	52
				15	3.4	BEF152809-4504-2QBH	6	30	48
				21	3.2	BEF152813-4504-3QBH	9	45	47
				30	2.1	BEF224320-4504-3EH(T)H	9	39	95
				44	2.5	BEF264622-0404-3EL(T)H	9	51	79
				54	3.0	BEF264622-0404-4EL(T)H	12	68	74
5 x 1.5	FLGÖU-J (MTGÖU-J)	12	0.23	66	2.8	BEF325524-0404-3DI(T)H	12	60	102
				6	1.9	BEF152809-4505-1QB	3	15	45
				12	2.3	BEF152813-4505-2QBH	6	30	45
				18	2.8	BEF152815-4505-3QBH	9	45	44
				30	1.9	BEF264622-0405-2EL(T)H	6	34	80
				44	2.2	BEF325524-0405-2DI(T)H	8	40	102
5 x 1.5	NSHTÖU-J	14.6	0.28	68	3.2	BEF325524-0405-3DI(T)H	12	60	102
				5	1.8	BEF152809-4505-1QB	3	15	41
				10	2.0	BEF152815-4505-2QBH	6	30	41
				20	2.1	BEF224320-4505-2EH(T)H	6	26	92
				32	2.4	BEF264622-0405-2EL(T)H	6	34	80
				45	2.6	BEF325524-0405-2DI(T)H	8	40	101
5 x 1.5	(SMK) (N)SHTÖU-J	13.8	0.28	70	3.8	BEF325524-0405-3DI(T)H	12	60	101
				9	2.8	BEF152809-4505-1QB	3	15	51
				17	3.0	BEF152815-4505-2QBH	6	30	49
				32	2.9	BEF224320-4505-3EH(T)H	9	39	94
				45	3.2	BEF264622-0405-3EL(T)H	9	51	76
				68	3.5	BEF325524-0405-3DI(T)H	12	60	100

Z = no. of conductors nv = required turns for spring preload Lw = winding length Fz = max. cable tension A = Cross-section na = max. working turns Lz = cable layers

Selection Tables for Reels

Application 1 and 3: Horizontal and Vertical Retrieval

Z x A [mm ²]	Cables Type	ø [mm]	m [kg/m]	Cable Length		Spring Cable Reel Spool - Slip Ring Assembly - Springs	Spring Motor		
				Lw [m]	Lz		nv	na	Fz [N]
5 x 1.5	PUR(NSHTÖU)	11.2	0.18	6	1.7	BEF152809-4505-1QB	3	15	46
				12	2.8	BEF152809-4505-2QBH	6	30	45
				25	2.0	BEF224320-4505-3IC(T)H	9	33	111
				45	2.7	BEF264622-0405-3EL(T)H	9	51	79
				67	3.1	BEF325524-0405-3DI(T)H	12	60	102
7 x 1.5	FLGÖU-J (MTGÖU-J)	13	0.28	5	1.6	BEF152809-4507-1QB	3	15	42
				11	2.9	BEF152809-4507-2QBH	6	30	42
				16	2.9	BEF152813-4507-2QBH	6	30	49
				20	1.8	BEF224320-4507-2EH(T)H	6	26	94
				31	2.7	BEF224320-4507-3EH(T)H	9	39	94
				38	2.6	BEF264622-0407-3EL(T)H	9	51	71
				54	2.8	BEF325524-0407-3DI(T)H	12	60	93
				70	3.4	BEF325524-0407-4DI(T)H	16	80	91
7 x 1.5	NSHTÖU-J	18	0.45	11	2.2	BEF183616-4507-2EI(T)H	4	16	100
				18	2.1	BEF224320-4507-2IC(T)H	6	22	108
				32	2.6	BEF264622-0407-3EL(T)H	23	37	71
				48	3.2	BEF325524-0407-2DI(T)H	8	40	101
				56	3.6	BEF325524-0407-3DI(T)H	12	60	90
				62	2.2	BEF508032-0407-2CC(T)H	6	36	126
				71	3.0	BEF508032-0407-2BD(T)H	8	50	152
7 x 1.5	(SMK) (N)SHTÖU-J	16.2	0.38	11	2.0	BEF183616-4507-2EI(T)H	4	16	103
				20	2.2	BEF224320-4507-2EH(T)H	6	26	91
				31	3.1	BEF224320-4507-3EH(T)H	9	39	90
				45	3.6	BEF264622-0407-4EL(T)H	30	50	76
				56	3.5	BEF325524-0407-3DI(T)H	12	60	91
				68	2.7	BEF406532-0407-3CC(T)H	9	54	152
7 x 1.5	PUR(NSHTÖU)	12.6	0.23	5	1.6	BEF152809-4507-1QB	3	15	42
				12	2.3	BEF152813-4507-2QBH	6	30	44
				21	2.0	BEF224320-4507-3IC(T)H	9	33	101
				32	2.2	BEF264622-0407-3EL(T)H	9	51	65
				56	3.5	BEF264622-0407-4EL(T)H	12	68	73
				70	3.5	BEF325524-0407-4DI(T)H	16	80	92
12 x 1.5	FLGÖU-J (MTGÖU-J)	19	0.52	8	1.2	BEF224320-4512-1IC(T)	3	11	104
				18	2.3	BEF224320-4512-2IC(T)H	6	22	106
				26	2.6	BEF264622-0412-2DH(T)H	8	27	125
				31	3.0	BEF264622-0412-3EL(T)H	29	31	80
				51	3.6	BEF325524-0412-3DI(T)H	21	51	94
				65	3.0	BEF406532-0412-3CC(T)H	9	54	145
12 x 1.5	NSHTÖU-J	21	0.65	12	1.5	BEF264622-0412-1DH(T)	4	14	122
				26	2.7	BEF264622-0412-2DH(T)H	8	27	122
				35	2.8	BEF325524-0412-2DI(T)H	14	34	94
				43	2.9	BEF406525-0412-2CC(T)H	6	36	143
				56	2.7	BEF406532-0412-3CC(T)H	9	54	133
				70	2.7	BEF508032-0412-2BD(T)H	8	50	180
12 x 1.5	(SMK)-(N)SHTÖU-J	22.4	0.71	12	1.3	BEF325524-0412-1DI(T)	4	20	79
				26	2.4	BEF325524-0412-2DI(T)H	17	31	89
				35	2.4	BEF406525-0412-2CC(T)H	6	36	129
				46	2.4	BEF406532-0412-2CC(T)H	6	36	148
				58	3.0	BEF406532-0412-3CC(T)H	9	54	134
				70	2.9	BEF508032-0412-2BD(T)H	8	50	179
12 x 1.5	PUR(NSHTÖU)	16.1	0.36	8	1.6	BEF183616-4512-2EI(T)H	4	16	90
				20	2.2	BEF224320-4512-2EH(T)H	6	26	91
				31	3.1	BEF224320-4512-3EH(T)H	9	39	90
				48	3.8	BEF264622-0412-4EL(T)H	27	53	76
				65	3.9	BEF325524-0412-3DI(T)H	12	60	96
				70	2.7	BEF406532-0412-3CC(T)H	9	54	154

Z = no. of conductors nv = required turns for spring preload Lw = winding length Fz = max. cable tension A = Cross-section na = max. working turns Lz = cable layers

Selection Tables for Reels

Application 1 and 3: Horizontal and Vertical Retrieval

Z x A [mm ²]	Cables Type	ø [mm]	m [kg/m]	Cable Length		Spring Cable Reel Spool - Slip Ring Assembly - Springs	Spring Motor		
				Lw [m]	Lz		nv	na	Fz [N]
18 x 1.5	FLGÖU-J (MTGÖU-J)	21	0.64	12	1.5	BEF264622-0418-1DH(T)	4	13.5	122
				26	2.7	BEF264622-0418-2DH(T)H	8	27	122
				36	2.9	BEF325524-0418-2DI(T)H	14	34	95
				44	2.9	BEF406525-0418-2CC(T)H	6	36	144
				63	3.0	BEF406532-0418-3CC(T)H	9	54	141
18 x 1.5	NSHTÖU-J	24.3	0.87	16	1.8	BEF325524-0418-1DI(T)	10	14	99
				28	2.7	BEF325524-0418-2MB(T)H	11	29	121
				41	2.9	BEF406525-0418-2CC(T)H	9	33	144
				68	3.0	BEF508032-0418-2BD(T)H	13	45	187
18 x 1.5	(SMK) (N)SHTÖU-J	22.3	0.76	16	1.6	BEF325524-0418-1DI(T)	6	18	91
				28	2.5	BEF325524-0418-2DI(T)H	21	27	95
				41	2.7	BEF406525-0418-2CC(T)H	6	36	139
				58	3.0	BEF406532-0418-3CC(T)H	12	51	139
18 x 1.5	PUR(NSHTÖU)	17	0.47	67	2.8	BEF508032-0418-2BD(T)H	9	49	177
				12	2.1	BEF183616-4518-2FD(T)H	9	19	63
				26	2.9	BEF224320-4518-3IC(T)H	9	33	104
				36	3.2	BEF264622-0418-3DH(T)H	12	40.5	121
				45	3.1	BEF325524-0418-2DI(T)H	8	40	99
24 x 1.5	FLGÖU-J (MTGÖU-J)	23	0.84	56	3.7	BEF325524-0418-3DI(T)H	13	59	91
				70	2.4	BEF508032-0418-2BD(T)H	8	50	185
				17	1.7	BEF325524-1824-1DI(T)	9	15	99
				26	2.4	BEF325524-1824-2MB(T)H	9	31	115
				36	2.7	BEF406525-1824-2CC(T)H	7	35	132
24 x 1.5	NSHTÖU-J	28	1.12	54	3.0	BEF406532-1824-3CC(T)H	15	48	139
				67	3.0	BEF508032-1824-2BD(T)H	12	46	184
				19	1.9	BEF406525-1824-1CC(T)	6	15	147
				32	1.8	BEF406525-1824-2CC(T)	17	25	186
24 x 1.5	(SMK) (N)SHTÖU-J	25.3	0.99	41	2.2	BEF406532-1824-2BE(T)H	6	29	192
				58	3.0	BEF508032-1824-2BD(T)H	22	36	193
				18	1.7	BEF406525-1824-1CC(T)	4	17	137
24 x 1.5	PUR(NSHTÖU)	21.5	0.59	32	2.6	BEF406525-1824-2CC(T)H	12	30	137
				46	2.7	BEF406532-1824-3CC(T)H	22	41	141
				62	3.0	BEF508032-1824-2BD(T)H	17	41	188
				15	1.8	BEF264622-1824-2EL(T)	3	17	149
				26	2.7	BEF264622-1824-2DH(T)H	8	27	122
				36	2.5	BEF406525-1824-2CC(T)H	6	36	131
30 x 1.5	NSHTÖU-J	30	1.32	47	2.5	BEF406532-1824-2CC(T)H	6	36	151
				57	2.4	BEF508032-1824-2CC(T)H	8	34	122
				66	2.8	BEF508032-1824-2BD(T)H	8	50	174
				17	1.7	BEF406525-1830-1CC(T)	8	13	150
				25	2.4	BEF406525-1830-2CC(T)	3	18	299
30 x 1.5	(SMK) (N)SHTÖU-J	28.1	1.22	32	2.4	BEF406532-1830-2BE(T)	7	28	199
				40	2.4	BEF508032-1830-2BE(T)H	13	22	204
				50	2.9	BEF508032-1830-2BD(T)H	28	30	197
				17	1.7	BEF406525-1830-1CC(T)	7	14	146
30 x 1.5	PUR(NSHTÖU)	23	0.71	25	1.8	BEF406532-1830-2CC(T)	3	18	308
				43	2.8	BEF406532-1830-2BE(T)H	6	29	257
				52	2.7	BEF508032-1830-2BD(T)H	24	34	191
				12	1.3	BEF325524-1830-1DI(T)	4	20	79
30 x 1.5	PUR(NSHTÖU)	23	0.71	24	2.2	BEF325524-1830-2DI(T)H	17	31	88
				38	2.8	BEF406525-1830-2CC(T)H	6	36	133
				54	3.0	BEF406532-1830-3CC(T)H	9	54	129
				70	3.1	BEF508032-1830-2BD(T)H	10	48	182

Z = no. of conductors nv = required turns for spring preload Lw = winding length Fz = max. cable tension A = Cross-section na = max. working turns Lz = cable layers

Selection Tables for Reels

Application 1 and 3: Horizontal and Vertical Retrieval

Z x A [mm ²]	Cables Type	ø [mm]	m [kg/m]	Cable Length		Spring Cable Reel Spool - Slip Ring Assembly - Springs	Spring Motor		
				Lw [m]	Lz		nv	na	Fz [N]
36 x 1.5	(SMK) (N)SHTÖU-J	28	1.26	15	1.6	BEF406525-1836-1CC(T)	7	14	140
				26	2.5	BEF406525-1836-2CC(T)	3	18	308
				35	2.4	BEF406532-1836-2BE(T)H	6	29	231
				44	2.9	BEF406532-1836-3BE(T)H	11	41	215
				58	3.0	BEF508032-1836-2BD(T)H	27	31	206
4 x 2.5	FLGÖU-J (MTGÖU-J)	13	0.32	8	2.3	BEF152809-4504-1QB	3	15	50
				16	2.9	BEF152813-4504-2QBH	6	30	49
				20	1.8	BEF224320-4504-2EH(T)H	6	26	94
				32	2.7	BEF224320-4504-3EH(T)H	9	39	95
				38	2.6	BEF264622-0404-3EL(T)H	10	50	72
				54	2.8	BEF325524-0404-3DI(T)H	12	60	93
				11	2.0	BEF183616-4504-2EI(T)H	4	16	103
4 x 2.5	NSHTÖU-J	16.2	0.35	17	1.9	BEF224320-4504-2IC(T)H	6	22	107
				28	2.9	BEF224320-4504-3IC(T)H	9	33	109
				40	3.2	BEF264622-0404-3EL(T)H	17	43	77
				57	3.5	BEF325524-0404-3DI(T)H	12	60	92
				70	2.7	BEF406532-0404-3CC(T)H	9	54	154
4 x 2.5	(SMK) (N)SHTÖU-J	14	0.3	11	1.7	BEF183616-4504-2FD(T)H	6	22	60
				17	1.7	BEF224320-4504-2IC(T)H	6	22	110
				28	2.6	BEF224320-4504-3EH(T)H	9	39	88
				40	2.9	BEF264622-0404-3EL(T)H	9	51	72
				56	3.8	BEF264622-0404-4EL(T)H	18	62	76
4 x 2.5	PUR	9	0.18	70	3.8	BEF325524-0404-3DI(T)H	12	60	101
				11	2.2	BEF152809-4504-2QBH	6	30	45
				20	2.7	BEF152813-4504-3QBH	9	45	48
				29	1.9	BEF224320-4504-3EH(T)H	9	39	96
				37	1.8	BEF264622-0404-3EL(T)H	9	51	73
4 x 2.5	PUR(NSHTÖU)	11.5	0.21	54	2.6	BEF264622-0404-4EL(T)H	12	68	76
				68	2.5	BEF325524-0404-4DI(T)H	16	80	94
				10	2.5	BEF152809-4504-2QBH	6	30	42
				15	2.6	BEF152813-4504-2QBH	6	30	49
				21	2.9	BEF152815-4504-3QBH	9	45	47
4 x 2.5	PUR(NSHTÖU)	11.5	0.21	30	2.4	BEF224320-4504-3EH(T)H	9	39	95
				42	2.5	BEF264622-0404-3EL(T)H	9	51	76
				56	3.2	BEF264622-0404-4EL(T)H	12	68	75
				67	3.1	BEF325524-0404-3DI(T)H	12	60	102
				11	2.0	BEF183616-4505-2EI(T)H	4	16	102
5 x 2.5	NSHTÖU-J	17.4	0.41	22	2.5	BEF224320-4505-2EH(T)H	6	26	93
				33	3.5	BEF224320-4505-3EH(T)H	9	39	91
				39	3.4	BEF264622-0405-3DH(T)H	12	41	124
				47	3.2	BEF325524-0405-2DI(T)H	8	40	100
				56	3.7	BEF325524-0405-3DI(T)H	12	60	90
5 x 2.5	(SMK) (N)SHTÖU-J	15	0.35	70	2.9	BEF406532-0405-3CC(T)H	9	54	152
				11	1.8	BEF183616-4505-2FD(T)H	6	22	59
				22	2.2	BEF224320-4505-3IC(T)H	9	33	100
				34	2.7	BEF264622-0405-3EL(T)H	13	47	69
				45	3.4	BEF264622-0405-4EL(T)H	23	57	72
5 x 2.5	PUR(NSHTÖU)	12.2	0.24	66	3.8	BEF325524-0405-3DI(T)H	12	60	98
				8	2.3	BEF152809-4505-1QB	3	15	50
				16	2.9	BEF152813-4505-2QBH	6	30	49
				26	2.2	BEF224320-4505-3IC(T)H	9	33	111
				38	2.4	BEF264622-0405-3EL(T)H	9	51	72
5 x 2.5	PUR(NSHTÖU)	12.2	0.24	55	3.3	BEF264622-0405-4EL(T)H	12	68	73
				69	3.3	BEF325524-0405-4DI(T)H	16	80	92

Z = no. of conductors nv = required turns for spring preload Lw = winding length Fz = max. cable tension A = Cross-section na = max. working turns Lz = cable layers

Selection Tables for Reels

Application 1 and 3: Horizontal and Vertical Retrieval

Z x A [mm ²]	Cables Type	ø [mm]	m [kg/m]	Cable Length		Spring Cable Reel Spool - Slip Ring Assembly - Springs	Spring Motor		
				Lw [m]	Lz		nv	na	Fz [N]
7 x 2.5	FLGÖU-J (MTGÖU-J)	15	0.39	10	1.7	BEF183616-4507-2EI(T)H	4	16	101
				21	2.1	BEF224320-4507-2EH(T)H	6	26	94
				33	3.1	BEF224320-4507-3EH(T)H	9	39	93
				39	3.0	BEF264622-0407-3EL(T)H	17	43	77
				46	2.8	BEF325524-0407-2DI(T)H	8	40	102
				69	3.9	BEF325524-0407-3DI(T)H	12	60	99
7 x 2.5	NSHTÖU-J	20.2	0.6	12	1.5	BEF264622-0407-1DH(T)	4	13.5	123
				27	2.8	BEF264622-0407-2DH(T)H	8	27	124
				39	3.1	BEF325524-0407-2DI(T)H	14	34	98
				46	2.8	BEF406525-0407-2CC(T)H	6	36	149
				62	3.0	BEF406532-0407-3CC(T)H	9	54	140
				70	2.8	BEF508032-0407-2BD(T)H	8	50	181
7 x 2.5	(SMK) (N)SHTÖU-J	17.6	0.51	12	1.6	BEF224320-4507-2IC(T)H	6	22	92
				23	2.6	BEF224320-4507-3IC(T)H	9	33	99
				34	3.0	BEF264622-0407-3DH(T)H	12	40.5	118
				58	3.8	BEF325524-0407-3DI(T)H	20	52	97
				69	2.8	BEF406532-0407-3CC(T)H	9	54	151
7 x 2.5	PUR(NSHTÖU)	13.3	0.31	9	2.5	BEF152809-4507-2QBH	6	30	40
				20	1.8	BEF224320-4507-2EH(T)H	6	26	94
				32	2.7	BEF224320-4507-3EH(T)H	9	39	95
				41	2.8	BEF264622-0407-3EL(T)H	9	51	73
				55	3.6	BEF264622-0407-4EL(T)H	18	62	76
				70	3.6	BEF325524-0407-3DI(T)H	12	60	102
12 x 2.5	FLGÖU-J (MTGÖU-J)	22	0.72	12	1.5	BEF264622-0412-1DH(T)	4	14	122
				25	2.7	BEF264622-0412-2DH(T)H	8	27	120
				33	2.9	BEF325524-0412-2DI(T)H	19	29	97
				42	2.8	BEF406525-0412-2CC(T)H	6	36	140
				63	3.2	BEF406532-0412-3CC(T)H	13	50	146
12 x 2.5	NSHTÖU-J	23.8	0.86	16	1.8	BEF325524-0412-1DI(T)	10	14	99
				28	2.7	BEF325524-0412-2MB(T)H	10	30	119
				41	3.0	BEF406525-0412-2CC(T)H	9	33	144
				55	3.0	BEF406532-0412-3CC(T)H	17	46	143
				70	3.1	BEF508032-0412-2BD(T)H	15	43	195
12 x 2.5	(SMK) (N)SHTÖU-J	24.4	0.92	28	2.7	BEF325524-0412-2MB(T)H	13	27	125
				42	2.4	BEF406532-0412-2CC(T)H	11	31	153
				55	3.0	BEF406532-0412-3CC(T)H	20	43	148
12 x 2.5	PUR	18	0.58	68	3.0	BEF508032-0412-2BD(T)H	15	43	192
				12	1.5	BEF224320-4512-2IC(T)H	6	22	92
				25	2.8	BEF224320-4512-3IC(T)H	9	33	102
				35	2.5	BEF325524-0412-2DI(T)H	11	37	93
				47	3.2	BEF325524-0412-3DI(T)H	26	46	96
12 x 2.5	PUR(NSHTÖU)	19.9	0.48	64	2.8	BEF406532-0412-3CC(T)H	9	54	145
				12	1.7	BEF224320-4512-2IC(T)H	6	22	90
				25	3.0	BEF224320-4512-3IC(T)H	9	33	99
				35	2.8	BEF325524-0412-2DI(T)H	8	40	88
				47	2.9	BEF406525-0412-2CC(T)H	6	36	151
18 x 2.5	FLGÖU-J (MTGÖU-J)	25	0.9	64	2.9	BEF406532-0412-3CC(T)H	9	54	143
				15	1.7	BEF325524-0418-1DI(T)	11	13	99
				27	2.6	BEF325524-0418-2MB(T)H	12	28	121
				42	3.0	BEF406525-0418-2CC(T)H	11	31	150
				51	3.0	BEF406532-0418-3CC(T)H	19	44	141
18 x 2.5	NSHTÖU-J	28.7	1.24	62	3.0	BEF508032-0418-2BD(T)H	14	44	180
				14	1.5	BEF406525-0418-1CC(T)	7	14	136
				27	2.5	BEF406525-0418-2CC(T)H	20	22	147
				40	2.6	BEF406532-0418-2BE(T)H	7	28	251
				58	3.0	BEF508032-0418-2BD(T)H	26	32	203

Z = no. of conductors nv = required turns for spring preload Lw = winding length Fz = max. cable tension A = Cross-section na = max. working turns Lz = cable layers

Selection Tables for Reels

Application 1 and 3: Horizontal and Vertical Retrieval

Z x A [mm ²]	Cables Type	ø [mm]	m [kg/m]	Cable Length		Spring Cable Reel Spool - Slip Ring Assembly - Springs	Spring Motor		
				Lw [m]	Lz		nv	na	Fz [N]
18 x 2.5	(SMK) (N)SHTÖU-J	24.3	1.05	14	1.4	BEF325524-0418-1DI(T)	6	18	87
				23	2.1	BEF325524-0418-2DI(T)	4	20	197
				34	2.9	BEF325524-0418-2MB(T)H	8	32	125
				43	2.8	BEF406525-0418-2CC(T)H	6	36	142
				56	2.9	BEF406532-0418-3CC(T)H	12	51	137
				70	2.9	BEF508032-0418-2BD(T)H	9	49	181
18 x 2.5	PUR	18	0.64	12	1.5	BEF224320-4518-2IC(T)H	6	22	92
				25	2.8	BEF224320-4518-3IC(T)H	11	31	105
				35	2.5	BEF325524-0418-2DI(T)H	15	33	98
				43	2.9	BEF325524-0418-3DI(T)H	27	45	94
				58	3.8	BEF325524-0418-3MB(T)H	12	48	134
				64	2.8	BEF406532-0418-3CC(T)H	9	54	145
18 x 2.5	PUR(NSHTÖU)	19.5	0.68	12	1.7	BEF224320-4518-2IC(T)H	6	22	90
				25	3.0	BEF224320-4518-3IC(T)H	14	28	108
				35	2.6	BEF325524-0418-2MB(T)H	8	32	130
				53	3.7	BEF325524-0418-3MB(T)H	16	44	134
				70	3.1	BEF406532-0418-3CC(T)H	14	49	158
24 x 2.5	FLGÖU-J (MTGÖU-J)	27	1.22	7	1.0	BEF325524-1824-1MB(T)	8	12	110
				21	2.4	BEF325524-1824-2DI(T)	4	20	184
				34	2.7	BEF406525-1824-2BE(T)H	6	29	225
				43	2.8	BEF406532-1824-2BE(T)H	6	29	257
				55	2.9	BEF508032-1824-2BD(T)H	24	34	195
24 x 2.5	(SMK) (N)SHTÖU-J	27.7	1.32	10	1.0	BEF406525-1824-1CC(T)	7	14	124
				22	1.9	BEF406525-1824-2CC(T)	3	18	286
				30	2.5	BEF406525-1824-2BE(T)H	6	29	212
				42	2.7	BEF406532-1824-3BE(T)H	12	40.5	214
				54	2.8	BEF508032-1824-2BD(T)H	28	30	204
				58	3.0	BEF508032-1824-2AB(T)H	8	40	324
24 x 2.5	PUR(NSHTÖU)	24.3	0.82	9	1.1	BEF325524-1824-1DI(T)	7	17	80
				20	2.1	BEF325524-1824-2DI(T)	4	20	184
				33	2.5	BEF406525-1824-2CC(T)H	7	35	127
				44	2.5	BEF406532-1824-2CC(T)H	8	34	148
				56	3.0	BEF406532-1824-3CC(T)H	15	48	139
				68	3.0	BEF508032-1824-2BD(T)H	11	47	181
30 x 2.5	PUR(NSHTÖU)	27.3	0.97	10	1.0	BEF406525-1830-1CC(T)	3	18	104
				25	2.1	BEF406525-1830-2CC(T)	3	18	305
				45	2.9	BEF406532-1830-3CC(T)H	22	41	138
				57	3.0	BEF508032-1830-2BD(T)H	16	42	177
36 x 2.5	PUR	25	1.3	5	0.7	BEF325524-1836-1DI(T)	17	7	94
				21	2.2	BEF325524-1836-2DI(T)	5	19	191
				34	2.5	BEF406525-1836-2BE(T)H	6	29	229
				51	3.0	BEF406532-1836-3BE(T)H	12	40.5	237
				10	1.5	BEF224320-4704-1EH(T)	3	13	91
4 x 4	NSHTÖU-J	19.1	0.49	18	2.3	BEF224320-4704-2IC(T)H	6	22	106
				31	3.0	BEF264622-0704-3EL(T)H	27	33	77
				38	2.8	BEF325524-0704-2DI(T)H	8	40	91
				51	3.6	BEF325524-0704-3DI(T)H	17	55	91
				69	3.1	BEF406532-0704-3CC(T)H	9	54	149
				70	2.9	BEF406532-0704-3CC(T)H	9	54	153
4 x 4	(SMK) (N)SHTÖU-J	17	0.45	10	1.8	BEF183616-4704-2EI(T)H	4	16	98
				18	2.2	BEF224320-4704-2IC(T)H	6	22	109
				29	3.2	BEF224320-4704-3IC(T)H	9	33	109
				39	2.7	BEF325524-0704-2DI(T)H	8	40	94
				59	3.8	BEF325524-0704-3DI(T)H	12	60	92
				70	2.9	BEF406532-0704-3CC(T)H	9	54	153

Z = no. of conductors nv = required turns for spring preload Lw = winding length Fz = max. cable tension A = Cross-section na = max. working turns Lz = cable layers

Selection Tables for Reels

Application 1 and 3: Horizontal and Vertical Retrieval

Z x A [mm ²]	Cables Type	ø [mm]	m [kg/m]	Cable Length		Spring Cable Reel Spool - Slip Ring Assembly - Springs	Spring Motor		
				Lw [m]	Lz		nv	na	Fz [N]
4 x 4	PUR	11.5	0.23	10	2.5	BEF152809-4704-2QBH	6	30	42
				20	1.6	BEF152813-4704-3QBH	9	33	100
				38	2.3	BEF264622-0704-3EL(T)H	9	51	72
				55	3.2	BEF264622-0704-4EL(T)H	12	68	74
				69	3.1	BEF325524-0704-4DI(T)H	16	80	92
4 x 4	PUR(NSHTÖU)	12.7	0.28	11	2.9	BEF152809-4704-2QBH	6	30	43
				27	2.4	BEF224320-4704-3EH(T)H	9	39	89
				42	2.7	BEF264622-0704-3EL(T)H	9	51	75
				53	3.3	BEF264622-0704-4EL(T)H	13	67	72
				67	3.3	BEF325524-0704-3DI(T)H	12	60	101
5 x 4	NSHTÖU-J	21.5	0.64	12	1.5	BEF264622-0705-1DH(T)	4	13.5	122
				25	2.6	BEF264622-0705-2DH(T)H	8	27	120
				36	2.5	BEF406525-0705-2CC(T)H	6	36	131
				55	2.8	BEF406532-0705-3CC(T)H	9	54	132
				64	2.7	BEF508032-0705-2BD(T)H	8	50	171
5 x 4	(SMK) (N)SHTÖU-J	18.4	0.43	12	2.3	BEF183616-4705-2FD(T)H	7	21	60
				26	2.6	BEF264622-0705-2EL(T)H	13	27	78
				44	3.2	BEF325524-0705-2DI(T)H	8	40	97
				55	3.9	BEF325524-0705-3DI(T)H	12	60	89
				68	2.9	BEF406532-0705-3CC(T)H	9	54	149
5 x 4	PUR(NSHTÖU)	13.8	0.32	12	2.5	BEF152813-4705-2QBH	6	30	44
				24	2.3	BEF224320-4705-3IC(T)H	9	33	106
				30	2.8	BEF224320-4705-3EH(T)H	9	39	92
				44	3.1	BEF264622-0705-3EL(T)H	13	47	79
				63	3.3	BEF325524-0705-3DI(T)H	12	60	97
4 x 6	NSHTÖU-J	20.7	0.61	12	1.5	BEF264622-0704-1DH(T)	4	13.5	123
				26	2.7	BEF264622-0704-2DH(T)H	8	27	122
				37	2.9	BEF325524-0704-2DI(T)H	11	37	93
				46	2.8	BEF406525-0704-2CC(T)H	6	36	148
				63	3.0	BEF406532-0704-3CC(T)H	9	54	141
4 x 6	(SMK) (N)SHTÖU-J	18.4	0.57	25	2.5	BEF264622-0704-2DH(T)H	8	27	123
				33	2.5	BEF325524-0704-2DI(T)H	10	38	90
				48	3.4	BEF325524-0704-3DI(T)H	26	46	96
				57	3.9	BEF325524-0704-3MB(T)H	12	48	132
				65	2.8	BEF406532-0704-3CC(T)H	9	54	146
4 x 6	PUR	13	0.32	70	2.5	BEF508032-0704-2BD(T)H	8	50	184
				5	1.6	BEF152809-4704-1QB	3	15	43
				17	2.8	BEF152815-4704-2QBH	6	30	51
				28	2.4	BEF224320-4704-3EH(T)H	9	39	90
				39	2.7	BEF264622-0704-3EL(T)H	10	50	73
4 x 6	PUR(NSHTÖU)	14	0.37	56	3.7	BEF264622-0704-4EL(T)H	19	61	78
				70	3.4	BEF325524-0704-4DI(T)H	16	80	91
				8	1.3	BEF183616-4704-2EI(T)H	4	16	92
				18	1.8	BEF224320-4704-2EH(T)H	6	26	89
				28	2.6	BEF224320-4704-3EH(T)H	9	39	88
5 x 6	(SMK) (N)SHTÖU-J	20	0.69	40	2.9	BEF264622-0704-3EL(T)H	15	45	77
				54	3.7	BEF264622-0704-4EL(T)H	26	54	81
				70	3.8	BEF325524-0704-3DI(T)H	12	60	101
				10	1.4	BEF224320-4705-2EH(T)	3	13	181
				23	2.8	BEF224320-4705-3IC(T)H	15	27	106
5 x 6	(SMK) (N)SHTÖU-J	20	0.69	36	2.9	BEF325524-0705-2MB(T)H	8	32	131
				49	3.0	BEF406525-0705-2CC(T)H	6	36	154
				70	3.1	BEF406532-0705-3CC(T)H	15	48	159

Z = no. of conductors nv = required turns for spring preload Lw = winding length Fz = max. cable tension A = Cross-section na = max. working turns Lz = cable layers

Selection Tables for Reels

Application 1 and 3: Horizontal and Vertical Retrieval

Z x A [mm ²]	Cables Type	ø [mm]	m [kg/m]	Cable Length		Spring Cable Reel Spool - Slip Ring Assembly - Springs	Spring Motor		
				Lw [m]	Lz		nv	na	Fz [N]
5 x 6	PUR(NSHTÖU)	15.3	0.43	9	1.6	BEF183616-4705-2EI(T)H	4	16	96
				20	2.1	BEF224320-4705-2EH(T)H	6	26	92
				31	2.9	BEF224320-4705-3EH(T)H	9	39	91
				43	3.2	BEF264622-0705-4EL(T)H	33	47	77
				54	3.9	BEF264622-0705-4DH(T)H	16	54	126
				68	3.9	BEF325524-0705-3DI(T)H	12	60	99
4 x 10	NSHTÖU-J	25	0.94	13	1.5	BEF325524-1504-1DI(T)	12	12	97
				24	2.4	BEF325524-1504-2DI(T)	4	20	196
				42	3.0	BEF406525-1504-2CC(T)H	12	30	152
				51	3.0	BEF406532-1504-3CC(T)H	21	42	144
4 x 10	(SMK) (N)SHTÖU-J	22.6	0.9	64	3.0	BEF508032-1504-2BD(T)H	17	41	191
				15	1.5	BEF325524-1504-1DI(T)	10	14	98
				26	2.4	BEF325524-1504-2MB(T)H	11	29	120
				34	2.9	BEF325524-1504-3MB(T)H	19	41	116
				44	2.9	BEF406525-1504-2CC(T)H	10	32	153
4 x 10	PUR	15.5	0.5	59	3.0	BEF406532-1504-3CC(T)H	19	44	152
				70	2.9	BEF508032-1504-2BD(T)H	14	44	194
				12	1.1	BEF264622-1504-1EL(T)	6	14	79
				26	2.1	BEF264622-1504-3EL(T)H	24	36	72
				38	2.9	BEF264622-1504-3DH(T)H	12	40.5	125
				51	3.7	BEF264622-1504-4DH(T)H	16	54	124
4 x 10	PUR(NSHTÖU)	17.9	0.61	61	3.5	BEF325524-1504-3DI(T)H	17	55	98
				70	4.0	BEF325524-1504-4DI(T)H	28	68	96
				12	1.3	BEF264622-1504-1DH(T)	4	13.5	125
				25	2.3	BEF264622-1504-2DH(T)H	8	27	124
				37	2.6	BEF325524-1504-2DI(T)H	14	34	98
				50	2.9	BEF406525-1504-2CC(T)H	6	36	158
5 x 10	(SMK) (N)SHTÖU-J	24.4	1.08	64	2.8	BEF406532-1504-3CC(T)H	9	54	145
				11	1.3	BEF325524-1505-1MB(T)	6	14	117
				24	2.4	BEF325524-1505-2DI(T)	4	20	197
				37	2.7	BEF406525-1505-2CC(T)H	15	27	153
				46	2.6	BEF406532-1505-3CC(T)H	26	37	148
				55	3.0	BEF406532-1505-3BE(T)H	9	43.5	237
5 x 10	PUR(NSHTÖU)	19.5	0.7	68	3.0	BEF508032-1505-2BD(T)H	21	37	207
				18	1.9	BEF264622-1505-2DH(T)	8	27	110
				28	2.7	BEF264622-1505-3DH(T)H	12	40.5	109
				38	2.8	BEF325524-1505-2MB(T)H	8	32	135
				52	3.6	BEF325524-1505-3MB(T)H	17	43	134
				68	3.1	BEF406532-1505-3CC(T)H	15	48	157
4 x 16	NSHTÖU-J	29	1.32	17	1.8	BEF406525-1604-1CC(T)	8	13	151
				25	1.8	BEF406532-1604-2CC(T)	3	18	307
				40	2.6	BEF406532-1604-2BE(T)H	8	27	256
				58	3.0	BEF508032-1604-2AB(T)H	8	40	322
4 x 16	(SMK) (N)SHTÖU-J	25.2	1.24	16	1.5	BEF406525-1604-1CC(T)	7	14	145
				24	2.1	BEF406525-1604-2CC(T)	3	18	302
				41	2.5	BEF406532-1604-2BE(T)H	6	29	255
				55	2.7	BEF508032-1604-2BD(T)H	24	34	197
				62	3.0	BEF508032-1604-2AB(T)H	8	40	340
4 x 16	PUR	19	0.8	19	1.2	BEF406525-1604-1CC(T)	3	18	141
				40	2.3	BEF406525-1604-2CC(T)H	7	35	143
				64	2.9	BEF406532-1604-3CC(T)H	17	46	157
4 x 16	PUR(NSHTÖU)	22.3	0.92	18	1.4	BEF406525-1604-1CC(T)	3	18	135
				33	2.3	BEF406525-1604-2CC(T)H	9	33	134
				41	2.2	BEF406532-1604-2CC(T)H	10	32	151
				53	2.7	BEF406532-1604-3CC(T)H	19	44	146
				65	2.7	BEF508032-1604-2BD(T)H	14	44	188

Z = no. of conductors nv = required turns for spring preload Lw = winding length Fz = max. cable tension A = Cross-section na = max. working turns Lz = cable layers

Selection Tables for Reels

Application 1 and 3: Horizontal and Vertical Retrieval

Z x A [mm ²]	Cables Type	ø [mm]	m [kg/m]	Cable Length		Spring Cable Reel Spool - Slip Ring Assembly - Springs	Spring Motor		
				Lw [m]	Lz		nv	na	Fz [N]
5 x 16	SMK (N)SHTÖU-J	27.6	1.5	16	1.5	BEF406525-1605-1BE(T)	3	14.5	227
				30	2.5	BEF406525-1605-2BE(T)H	9	26	228
				43	2.8	BEF406532-1605-3BE(T)H	16	36.5	230
				58	3.0	BEF508032-1605-2AB(T)H	8	40	324
5 x 16	PUR (NSHTÖU)S	24.3	1.07	21	1.7	BEF406525-1605-1CC(T)	5	16	153
				33	2.5	BEF406525-1605-2CC(T)H	14	28	144
				45	2.5	BEF406532-1605-3CC(T)H	25	38	146
				54	2.9	BEF406532-1605-3BE(T)H	9	43.5	235
				63	2.8	BEF508032-1605-2BD(T)H	20	38	199
4 x 25	SMK (N)SHTÖU-J	30	1.85	13	1.4	BEF406525-1904-1BE(T)	5	12.5	223
				22	1.7	BEF406532-1904-2CC(T)	3	18	285
				30	1.9	BEF508032-1904-1AB(T)	4	20	337
				44	2.6	BEF508032-1904-2BD(T)	5	24	408
4 x 25	PUR (NSHTÖU)S	25.8	1.27	53	3.0	BEF508032-1904-2AB(T)H	13	35	333
				13	1.3	BEF406525-1904-1CC(T)	7	14	135
				25	2.1	BEF406525-1904-2CC(T)	3	18	307
				37	2.9	BEF406525-1904-2BE(T)H	6	29	236
				49	2.9	BEF406532-1904-3BE(T)H	11	41.5	228
4 x 35	PUR (NSHTÖU)S	28.3	1.72	58	2.8	BEF508032-1904-2BD(T)H	26	32	206
				18	1.8	BEF406525-1904-2CC(T)	3	18	259
				29	2.7	BEF406525-1904-2BE(T)H	12	23	239
				44	2.8	BEF406532-1904-3BE(T)H	21	31.5	250
19 x 2.5 + 5 x 1 (C)	SMK (N)SHTÖU-J	27.7	1.29	55	2.9	BEF508032-1904-2AB(T)H	10	38	326
				10	1.0	BEF406525-1824-1CC(T)	7	14	124
				21	1.9	BEF406525-1824-2CC(T)	3	18	280
				31	2.5	BEF406525-1824-2BE(T)H	6	29	215
				44	2.8	BEF406532-1824-3BE(T)H	11	41.5	215
26 x 2.5 + 4 x 2.5 (C)	PUR	24.5	1.22	58	3.0	BEF508032-1824-2AB(T)H	8	40	324
				12	1.4	BEF325524-1830-1DI(T)	13	11	98
				25	2.5	BEF325524-1830-2MB(T)H	16	24	126
				41	2.9	BEF406525-1830-2CC(T)H	13	29	154
3 x 25 + 3G6	PUR	21.5	1.04	51	2.8	BEF406532-1830-3CC(T)H	24	39	150
				68	3.0	BEF508032-1830-2BD(T)H	18	40	200
				18	1.4	BEF406525-1904-1CC(T)	4	17	140
				34	2.4	BEF406525-1904-2CC(T)H	12	30	143
				44	2.4	BEF406532-1904-3CC(T)H	22	41	142
3 x 35 + 3 x 16/3	SMK (N)SHTÖU-J	30	2.16	62	3.2	BEF406532-1904-3BE(T)H	9	43.5	258
				70	2.9	BEF508032-1904-2BD(T)H	19	39	208
				12	1.3	BEF406525-1904-1BE(T)	7	10.5	238
				23	1.8	BEF406532-1904-2CC(T)	5	16	311
3 x 35 + 3G6	PUR	25	1.41	30	1.9	BEF508032-1904-1AB(T)	6	18	359
				53	3.0	BEF508032-1904-2AB(T)H	18	30	362
				14	1.2	BEF406525-1904-1CC(T)	8	13	144
				22	1.8	BEF406525-1904-2CC(T)	3	18	291
				30	2.3	BEF406525-1904-2BE(T)H	7	28	222
				43	2.6	BEF406532-1904-3BE(T)H	13	39.5	224
				52	2.6	BEF508032-1904-2BD(T)H	29	29	207

Z = no. of conductors nv = required turns for spring preload Lw = winding length Fz = max. cable tension A = Cross-section na = max. working turns Lz = cable layers

The reel types presented in these tables have been categorised according to their maximum spring forces, maximum winding capabilities and maximum permissible cable tension. The part numbers all refer to the standard reel which unwinds counterclockwise.

Selection Tables for Reels

Application 4: Vertical Lift (Reel on top)

Application 4

Vertical lift

(Reel is mounted stationary and cable is unwound vertically downward)

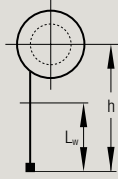

Note: For the dimensioning it was assumed that **h** is not longer than **L_w**. Additional weight on the cable has not been taken into account.

Maximum Unspooling Speed, $v_{\max} = 63 \text{ m/min}$;
Maximum Acceleration, $b_{\max} = 0.3 \text{ m/sec}^2$

Z x A [mm ²]	Cables Type	ø [mm]	m [kg/m]	Cable Length		Spring Cable Reel Spool - Slip Ring Assembly - Springs	Spring Motor		
				L _w [m]	L _z		nv	na	F _z [N]
7 x 1.0	FLGÖU-J (MTGÖU-J)	14	0.24	4	1.6	BEF152809-4507-1QB	3	15	39
				12	2.5	BEF152813-4507-2UAH	6	22	84
				17	3.0	BEF152815-4507-3UAH	9	33	80
				24	2.3	BEF224320-4507-3IC(T)H	9	33	105
12 x 1.0	FLGÖU-J (MTGÖU-J)	15.9	0.4	9	1.6	BEF183616-4512-2EI(T)H	4	16	95
				15	1.7	BEF224320-4512-2IC(T)H	6	22	102
				23	1.6	BEF325524-0412-2MB(T)H	17	23	132
				28	1.5	BEF406525-0412-2CC(T)H	18	24	153
18 x 1.0	FLGÖU-J (MTGÖU-J)	17.3	0.49	12	1.6	BEF224320-4518-2IC(T)H	6	22	92
				17	1.7	BEF264622-0418-2DH(T)H	16	19	126
				21	1.6	BEF325524-0418-2DI(T)	4	20	197
				23	1.4	BEF406525-0418-1CC(T)	3	18	156
24 x 1.0	FLGÖU-J (MTGÖU-J)	20.6	0.66	40	2.2	BEF406525-0418-2BE(T)H	6	29	265
				9	1.2	BEF264622-1824-1DH(T)	4	14	110
				19	1.7	BEF325524-1824-2DI(T)	4	20	186
				24	1.6	BEF406525-1824-2CC(T)	3	18	313
36 x 1.0	FLGÖU-J (MTGÖU-J)	24.3	0.96	29	1.9	BEF406525-1824-2BE(T)H	12	23	252
				10	1.2	BEF325524-1836-2DI(T)	4	20	150
				19	2.0	BEF325524-1836-3DI(T)	4	20	271
				25	2.0	BEF406525-1836-2CC(T)	3	18	315
3 x 1.5	FLGÖU-J (MTGÖU-J)	10	0.14	28	1.4	BEF508032-1836-3CC(T)	3	18	355
				6	1.5	BEF152109-4503-1QB	3	15	47
				14	3.0	BEF152809-4503-2QBH	6	30	48
				21	3.0	BEF152813-4503-3QBH	9	45	48
4 x 1.5	FLGÖU-J (MTGÖU-J)	11	0.22	32	1.7	BEF264622-0403-3EL(T)H	9	51	67
				12	2.9	BEF152809-4504-2QBH	6	30	45
				17	1.4	BEF224320-4504-2EH(T)H	6	26	90
				26	2.0	BEF224320-4504-3EH(T)H	9	39	89
4 x 1.5	NSHTÖU-J	13.5	0.24	5	1.8	BEF152809-4504-1QB	3	15	42
				11	2.3	BEF152813-4504-2QBH	6	30	43
				17	2.8	BEF152815-4504-3UAH	9	33	81
				21	2.0	BEF224320-4504-3IC(T)H	9	33	100
				27	2.5	BEF224320-4504-3EH(T)H	13	35	92
				31	2.2	BEF264622-0404-3DH(T)H	12	41	119
4 x 1.5	SMK (N)SHTÖU-J	13	0.24	3	1.1	BEF152809-4504-1QB	3	15	37
				11	2.9	BEF152809-4504-2QBH	6	30	42
				17	2.8	BEF152815-4504-3UAH	9	33	82
				20	1.8	BEF224320-4504-2EH(T)H	6	26	94
				27	2.4	BEF224320-4504-3EH(T)H	12	36	92
				32	2.3	BEF264622-4504-3DH(T)H	12	41	120
4 x 1.5	PUR (NSHTÖU)S	10.5	0.15	4	1.7	BEF152109-4504-1QB	3	15	46
				14	3.2	BEF152809-4504-2QBH	6	30	47
				21	3.2	BEF152813-4504-3QBH	9	45	47
				30	2.1	BEF224320-4504-3EH(T)H	9	39	95
5 x 1.5	FLGÖU-J (MTGÖU-J)	12	0.23	4	1.4	BEF152809-4505-1QB	3	15	40
				15	2.8	BEF152813-4505-2QBH	6	30	48
				20	1.7	BEF224320-4505-2EH(T)H	6	26	95
				28	2.3	BEF224320-4505-3EH(T)H	10	38	92

Z = no. of conductors nv = required turns for spring preload L_w = winding length F_z = max. cable tension A = Cross-section na = max. working turns L_z = cable layers

Selection Tables for Reels

Application 4: Vertical Lift (Reel on top)

Z x A [mm ²]	Cables Type	ø [mm]	m [kg/m]	Cable Length		Spring Cable Reel Spool - Slip Ring Assembly - Springs	Spring Motor		
				Lw [m]	Lz		nv	na	Fz [N]
5 x 1.5	NSHTÖU-J	14.6	0.28	5	1.0	BEF183616-4505-1EI(T)	2	8	104
				11	1.8	BEF183616-4505-2FD(T)H	6	22	59
				18	1.9	BEF224320-4505-2EH(T)H	6	26	88
				28	2.1	BEF264622-0405-3DH(T)H	16	37	119
				35	1.7	BEF406525-0405-2CC(T)H	6	36	136
5 x 1.5	(SMK) (N)SHTÖU-J	13.8	0.28	5	1.8	BEF152809-4505-1QB	3	15	42
				11	2.3	BEF152813-4505-2QBH	8	28	44
				18	1.8	BEF224320-4505-2EH(T)H	6	26	89
				27	2.5	BEF224320-4505-3IC(T)H	9	33	111
				35	1.6	BEF406525-0405-2CC(T)H	6	36	137
5 x 1.5	PUR(NSHTÖU)	11.2	0.18	5	1.4	BEF152809-4505-1QB	3	15	43
				13	3.0	BEF152809-4505-2QBH	6	30	46
				20	3.3	BEF152813-4505-3QBH	19	35	51
				30	2.3	BEF224320-4505-3EH(T)H	9	39	94
7 x 1.5	FLGÖU-J (MTGÖU-J)	13	0.28	4	1.4	BEF152809-4507-1QB	3	15	39
				12	2.3	BEF152813-4507-2QBH	10	26	47
				17	2.8	BEF152815-4507-3UAH	9	33	82
				20	1.8	BEF224320-4507-2EH(T)H	6	26	94
				26	2.3	BEF224320-4507-3IC(T)H	9	33	110
				30	2.2	BEF264622-0407-3DH(T)H	19	34	127
				37	1.6	BEF406525-0407-2CC(T)H	6	36	141
7 x 1.5	NSHTÖU-J	18	0.45	5	1.2	BEF183616-4507-1EI(T)	2	8	100
				11	2.2	BEF183616-4507-2EI(T)H	6	14	101
				17	2.0	BEF224320-4507-2IC(T)H	6	22	105
				22	1.7	BEF325524-0407-2DI(T)	4	20	200
				26	1.6	BEF406525-0407-2CC(T)H	22	20	158
7 x 1.5	(SMK) (N)SHTÖU-J	16.2	0.38	5	1.1	BEF183616-4507-1EI(T)	2	8	102
				11	2.0	BEF183616-4507-2EI(T)H	4	16	103
				17	1.9	BEF224320-4507-2IC(T)H	6	22	107
				22	1.6	BEF325524-0407-2DI(T)	4	20	202
				29	1.6	BEF406525-0407-2CC(T)H	17	25	152
7 x 1.5	PUR(NSHTÖU)	12.6	0.23	9	2.5	BEF152809-4507-2QBH	6	30	40
				17	2.8	BEF152815-4507-3UAH	9	33	82
				20	1.8	BEF224320-4507-2EH(T)H	6	26	94
				27	2.4	BEF224320-4507-3EH(T)H	9	39	89
12 x 1.5	FLGÖU-J (MTGÖU-J)	19	0.52	32	2.2	BEF264622-0407-3DH(T)H	12	41	121
				9	1.3	BEF224320-4512-1EH(T)	3	13	87
				15	2.0	BEF224320-4512-2IC(T)H	9	19	106
				22	1.8	BEF325524-0412-2DI(T)	4	20	199
12 x 1.5	NSHTÖU-J	21	0.65	33	2.0	BEF406525-0412-2BE(T)H	6	29	236
				12	1.5	BEF264622-0412-1DH(T)	4	14	122
				16	1.9	BEF264622-0412-2EL(T)	3	17	155
				20	1.8	BEF325524-0412-2DI(T)	5	19	193
				23	2.0	BEF325524-0412-3DI(T)	4	20	299
12 x 1.5	(SMK) (N)SHTÖU-J	22.4	0.71	26	1.9	BEF406525-0412-2BE(T)H	9	26	224
				11	1.5	BEF264622-0412-1DH(T)	4	14	117
				16	2.0	BEF264622-0412-2EL(T)	4	16	156
				19	1.8	BEF325524-0412-2DI(T)	8	16	199
				23	2.1	BEF325524-0412-3DI(T)	4	20	295
				26	1.9	BEF406525-0412-2BE(T)H	13	22	244
				37	1.7	BEF508032-0412-2BD(T)	4	25	380

Z = no. of conductors nv = required turns for spring preload Lw = winding length Fz = max. cable tension A = Cross-section na = max. working turns Lz = cable layers

Selection Tables for Reels

Application 4: Vertical Lift (Reel on top)

Z x A [mm ²]	Cables Type	ø [mm]	m [kg/m]	Cable Length		Spring Cable Reel Spool - Slip Ring Assembly - Springs	Spring Motor		
				Lw [m]	Lz		nv	na	Fz [N]
12 x 1.5	PUR(NSHTÖU)	16.1	0.36	5	1.1	BEF183616-4512-1E(T)	2	8	102
				12	2.1	BEF183616-4512-2FD(T)H	9	19	64
				18	2.0	BEF224320-4512-2EH(T)H	9	23	92
				21	2.3	BEF224320-4512-3IC(T)H	13	29	104
				23	2.0	BEF264622-0412-2DH(T)H	9	26	124
				40	1.7	BEF406532-0412-3BE(T)H	9	44	216
18 x 1.5	FLGÖU-J (MTGÖU-J)	21	0.64	12	1.5	BEF264622-0418-1DH(T)	4	14	122
				16	1.9	BEF264622-0418-2EL(T)	3	17	155
				21	1.8	BEF325524-0418-2DI(T)	6	18	200
				23	2.0	BEF325524-0418-3DI(T)	4	20	299
				27	1.9	BEF406525-0418-2BE(T)H	9	26	227
				40	1.7	BEF508032-0418-2BD(T)	4	25	400
18 x 1.5	NSHTÖU-J	24.3	0.87	8	1.0	BEF325524-0418-1MB(T)	5	15	103
				18	1.9	BEF325524-0418-2MB(T)	4	16	262
				23	2.3	BEF325524-0418-3DI(T)	4	20	291
				30	1.5	BEF508032-0418-1AB(T)	6	18	376
				34	1.7	BEF508032-0418-3BD(T)	4	25	539
18 x 1.5	(SMK) (N)SHTÖU-J	22.3	0.76	8	0.9	BEF325524-0418-1DI(T)	14	10	94
				18	1.8	BEF325524-0418-2MB(T)	4	16	266
				23	2.1	BEF325524-0418-3DI(T)	4	20	296
				30	1.4	BEF508032-0418-1AB(T)	4	20	351
				39	1.8	BEF508032-0418-2BD(T)	7	22	417
18 x 1.5	PUR(NSHTÖU)	17	0.47	8	1.6	BEF183616-4518-2E(T)H	4	16	89
				17	2.1	BEF224320-4518-2IC(T)H	7	21	108
				22	1.7	BEF325524-0418-2DI(T)	4	20	201
				25	1.5	BEF406525-0418-2CC(T)H	23	19	160
				40	2.2	BEF406525-0418-2BE(T)H	6	29	265
24 x 1.5	FLGÖU-J (MTGÖU-J)	23	0.84	9	1.0	BEF325524-1824-1MB(T)	6	14	111
				18	1.8	BEF325524-1824-2MB(T)	4	16	265
				23	2.1	BEF325524-1824-3DI(T)	4	20	294
				29	1.5	BEF508032-1824-1AB(T)	5	19	355
				35	1.7	BEF508032-1824-2BD(T)	9	20	416
24 x 1.5	NSHTÖU-J	28	1.12	13	1.4	BEF406525-1824-1BE(T)	3	15	204
				20	2.0	BEF406525-1824-2CC(T)	6	15	301
				24	1.7	BEF406532-1824-3CC(T)	3	18	453
				32	1.8	BEF508032-1824-2AB(T)	4	20	705
24 x 1.5	(SMK) (N)SHTÖU-J	25.3	0.99	13	1.3	BEF406525-1824-1BE(T)	3	15	207
				21	1.9	BEF406525-1824-2CC(T)	3	18	283
				24	1.3	BEF508032-1824-2BE(T)	3	15	405
				32	1.7	BEF508032-1824-2AB(T)	4	20	716
24 x 1.5	PUR(NSHTÖU)	21.5	0.59	12	1.5	BEF264622-1824-1DH(T)	4	14	122
				16	1.9	BEF264622-1824-2EL(T)	3	17	155
				21	2.0	BEF325524-1824-2DI(T)	4	20	191
				24	1.8	BEF406525-1824-2CC(T)	3	18	311
				27	1.9	BEF406525-1824-2BE(T)H	6	29	211
				40	1.8	BEF508032-1824-2BD(T)	4	25	398
30 x 1.5	NSHTÖU-J	30	1.32	13	1.4	BEF406525-1830-1BE(T)	6	12	234
				20	2.0	BEF406525-1830-2BE(T)	3	15	499
				24	1.6	BEF508032-1830-2BE(T)	4	14	410
				32	2.0	BEF508032-1830-2AB(T)	4	20	696
30 x 1.5	(SMK) (N)SHTÖU-J	28.1	1.22	11	1.3	BEF406525-1830-1BE(T)	3	15	190
				21	2.1	BEF406525-1830-2BE(T)	3	15	517
				32	1.8	BEF508032-1830-2AB(T)	4	20	705

Z = no. of conductors nv = required turns for spring preload Lw = winding length Fz = max. cable tension A = Cross-section na = max. working turns Lz = cable layers

Selection Tables for Reels

Application 4: Vertical Lift (Reel on top)

Z x A [mm ²]	Cables Type	ø [mm]	m [kg/m]	Cable Length		Spring Cable Reel Spool - Slip Ring Assembly - Springs	Spring Motor		
				Lw [m]	Lz		nv	na	Fz [N]
30 x 1.5	PUR(NSHTÖU)	23	0.71	11	1.2	BEF325524-1830-1MB(T)	5	15	114
				19	1.8	BEF325524-1830-2DI(T)	8	16	199
				24	1.9	BEF406525-1830-2CC(T)	3	18	307
				29	1.5	BEF508032-1830-1AB(T)	4	20	343
				38	1.8	BEF508032-1830-2BD(T)	4	25	383
36 x 1.5	(SMK) (N)SHTÖU-J	28	1.26	10	1.2	BEF406525-1836-1BE(T)	3	14.5	182
				21	1.6	BEF406532-1836-3CC(T)	3	18	434
				33	1.9	BEF508032-1836-2AB(T)	4	20	717
4 x 2.5	FLGÖU-J (MTGÖU-J)	13	0.32	9	2.5	BEF152809-4504-2QBH	7	29	41
				17	2.8	BEF152815-4504-3UAH	9	33	82
				20	1.8	BEF224320-4504-2EH(T)H	6	26	94
				24	1.8	BEF264622-0404-2DH(T)H	8	27	128
				31	1.3	BEF406525-0404-2CC(T)H	8	34	135
4 x 2.5	NSHTÖU-J	16.2	0.35	5	1.1	BEF183616-4504-1EI(T)	2	8	102
				11	2.0	BEF183616-4504-2EI(T)H	4	16	103
				18	2.0	BEF224320-4504-2EH(T)H	7	25	89
				24	2.1	BEF264622-0404-2DH(T)H	9	26	126
				34	1.8	BEF406525-0404-2CC(T)H	17	25	160
				37	1.3	BEF508032-0404-1BD(T)	4	25	196
4 x 2.5	(SMK) (N)SHTÖU-J	14	0.3	5	0.9	BEF183616-4504-1FD(T)	3	11	59
				11	1.7	BEF183616-4504-2FD(T)H	6	22	60
				18	1.8	BEF224320-4504-2EH(T)H	6	26	89
				24	2.3	BEF224320-4504-3IC(T)H	9	33	105
				34	1.6	BEF406525-0404-2CC(T)H	8	34	140
4 x 2.5	PUR	9	0.18	37	1.1	BEF508032-0404-1BD(T)	4	25	198
				5	1.2	BEF152109-4504-1QB	3	15	44
				12	2.4	BEF152809-4504-2QBH	6	30	46
				17	2.4	BEF152813-4504-3QBH	9	45	45
				26	1.7	BEF224320-4504-3EH(T)H	9	39	91
				35	1.7	BEF264622-0404-3DH(T)H	12	41	130
4 x 2.5	PUR(NSHTÖU)	11.5	0.21	40	1.5	BEF325524-0404-3MB(T)H	12	48	125
				6	1.7	BEF152809-4504-1QB	3	15	46
				12	2.8	BEF152809-4504-2QBH	6	30	44
				19	3.1	BEF152813-4504-3UAH	9	33	87
				31	2.4	BEF224320-4504-3EH(T)H	9	39	96
5 x 2.5	NSHTÖU-J	17.4	0.41	37	2.2	BEF264622-0404-3DH(T)H	12	41	130
				5	1.1	BEF183616-4505-1EI(T)	2	8	101
				11	2.0	BEF183616-4505-2EI(T)H	4	16	102
				19	2.2	BEF224320-4505-3IC(T)H	18	24	107
				23	1.7	BEF325524-0405-2MB(T)H	19	21	135
				28	1.6	BEF406525-0405-2CC(T)H	20	22	157
5 x 2.5	(SMK) (N)SHTÖU-J	15	0.35	35	2.0	BEF406525-0405-2BE(T)H	6	29	247
				5	1.0	BEF183616-4505-1EI(T)	2	8	104
				11	1.8	BEF183616-4505-2FD(T)H	6	22	59
				19	2.0	BEF224320-4505-2EH(T)H	8	24	94
				21	1.8	BEF264622-0405-2DH(T)H	8	27	119
				23	1.5	BEF325524-0405-2MB(T)H	9	31	117
				28	1.4	BEF406525-0405-2CC(T)H	10	32	133
5 x 2.5	PUR(NSHTÖU)	12.2	0.24	39	1.9	BEF406525-0405-2BE(T)H	6	29	266
				6	1.8	BEF152809-4505-1QB	3	15	45
				15	2.8	BEF152813-4505-2QBH	9	27	51
				19	2.9	BEF152815-4505-3UAH	9	33	87
				26	2.2	BEF224320-4505-3IC(T)H	9	33	111
				35	2.2	BEF264622-0405-3DH(T)H	13	40	127

Z = no. of conductors nv = required turns for spring preload Lw = winding length Fz = max. cable tension A = Cross-section na = max. working turns Lz = cable layers

Selection Tables for Reels

Application 4: Vertical Lift (Reel on top)

Z x A [mm ²]	Cables Type	ø [mm]	m [kg/m]	Cable Length		Spring Cable Reel Spool - Slip Ring Assembly - Springs	Spring Motor		
				Lw [m]	Lz		nv	na	Fz [N]
7 x 2.5	FLGÖU-J (MTGÖU-J)	15	0.39	5	1.0	BEF183616-4507-1EI(T)	2	8	104
				11	1.8	BEF183616-4507-2FD(T)H	9	19	63
				17	1.8	BEF224320-4507-2IC(T)H	6	22	109
				21	1.8	BEF264622-0407-2DH(T)H	10	25	123
				29	1.5	BEF406525-0407-2CC(T)H	17	25	153
				39	1.9	BEF406525-0407-2BE(T)H	6	29	266
7 x 2.5	NSHTÖU-J	20.2	0.6	12	1.5	BEF264622-0407-1DH(T)	3	15	123
				16	1.9	BEF264622-0407-2EL(T)	3	17	156
				22	1.9	BEF325524-0407-2DI(T)	4	20	197
				27	1.8	BEF406525-0407-2BE(T)H	6	29	213
				33	1.7	BEF406532-0407-2BE(T)H	11	24	263
7 x 2.5	(SMK) (N)SHTÖU-J	17.6	0.51	12	1.3	BEF264622-0407-1DH(T)	4	14	126
				16	1.6	BEF264622-0407-2DH(T)H	16	19	123
				22	1.7	BEF325524-0407-2DI(T)	4	20	201
				27	1.6	BEF406525-0407-2BE(T)H	6	29	216
7 x 2.5	PUR(NSHTÖU)	13.3	0.31	9	2.5	BEF152809-4507-2QBH	6	30	40
				15	3.0	BEF152813-4507-3UAH	9	33	76
				23	2.1	BEF224320-4507-3IC(T)H	9	33	104
				27	2.0	BEF264622-0407-3DH(T)H	22	31	127
				33	1.5	BEF406525-0407-2CC(T)H	8	34	139
				40	1.4	BEF406532-0407-3BE(T)H	9	44	220
12 x 2.5	FLGÖU-J (MTGÖU-J)	22	0.72	10	1.3	BEF264622-0412-1DH(T)	4	14	114
				15	1.8	BEF264622-0412-2EL(T)	4	16	154
				18	1.8	BEF325524-0412-2DI(T)	7	17	193
				23	2.2	BEF325524-0412-3DI(T)	4	20	296
				30	1.4	BEF508032-0412-1AB(T)	4	20	352
				35	1.6	BEF508032-0412-2BD(T)	4	25	369
12 x 2.5	NSHTÖU-J	23.8	0.86	9	1.1	BEF325524-0412-1MB(T)	7	13	114
				18	1.9	BEF325524-0412-2MB(T)	4	16	263
				23	2.3	BEF325524-0412-3DI(T)	4	20	291
				28	1.4	BEF508032-0412-1AB(T)	5	19	347
				41	2.0	BEF508032-0412-3BD(T)	4	25	598
12 x 2.5	(SMK) (N)SHTÖU-J	24.4	0.92	9	1.1	BEF325524-0412-1MB(T)	9	11	122
				18	1.9	BEF325524-0412-2MB(T)	4	16	261
				22	2.3	BEF325524-0412-3DI(T)	6	18	297
				28	1.4	BEF508032-0412-1AB(T)	7	17	369
12 x 2.5	PUR	18	0.58	41	1.9	BEF508032-0412-3BD(T)	4	25	597
				13	1.7	BEF224320-4512-2IC(T)H	10	18	104
				17	1.3	BEF325524-0412-2DI(T)	4	20	182
				23	1.5	BEF406525-0412-2CC(T)	3	18	311
				32	1.9	BEF406525-0412-2BE(T)H	8	27	245
12 x 2.5	PUR(NSHTÖU)	19.9	0.48	40	1.5	BEF508032-0412-2BD(T)	4	25	406
				10	1.4	BEF224320-4512-1EH(T)	3	13	90
				16	2.1	BEF224320-4512-2IC(T)H	8	20	105
				20	1.8	BEF325524-0412-2DI(T)	4	20	190
				24	1.6	BEF406525-0412-1CC(T)	3	18	157
				36	2.3	BEF406525-0412-2BE(T)H	6	29	245
18 x 2.5	FLGÖU-J (MTGÖU-J)	25	0.9	8	1.0	BEF325524-0418-1MB(T)	6	14	106
				18	1.9	BEF325524-0418-2MB(T)	4	16	261
				22	2.2	BEF325524-0418-3DI(T)	5	19	291
				24	1.9	BEF406525-0418-2CC(T)	3	18	304
				27	1.5	BEF508032-0418-1AB(T)	6	18	350
				41	2.1	BEF508032-0418-3BD(T)	4	25	593

Z = no. of conductors nv = required turns for spring preload Lw = winding length Fz = max. cable tension A = Cross-section na = max. working turns Lz = cable layers

Selection Tables for Reels

Application 4: Vertical Lift (Reel on top)

Z x A [mm ²]	Cables Type	ø [mm]	m [kg/m]	Cable Length		Spring Cable Reel Spool - Slip Ring Assembly - Springs	Spring Motor		
				Lw [m]	Lz		nv	na	Fz [N]
18 x 2.5	NSHTÖU-J	28.7	1.24	13	1.4	BEF406525-0418-1BE(T)	4	14	214
				21	2.1	BEF406525-0418-2BE(T)	3	15	515
				25	1.5	BEF508032-0418-2BE(T)	3	15	409
				33	1.9	BEF508032-0418-2AB(T)	4	20	715
18 x 2.5	(SMK) (N)SHTÖU-J	24.3	1.05	13	1.5	BEF325524-0418-2DI(T)	12	12	195
				20	2.1	BEF325524-0418-3DI(T)	7	17	296
				26	1.3	BEF508032-0418-1AB(T)	9	15	377
				33	1.6	BEF508032-0418-2AB(T)	4	20	733
18 x 2.5	PUR	18	0.64	12	1.5	BEF224320-4518-2IC(T)H	12	16	106
				15	1.5	BEF264622-0418-2EL(T)	3	17	155
				20	1.5	BEF325524-0418-2DI(T)	4	20	193
				24	1.5	BEF406525-0418-2CC(T)	3	18	318
				27	1.7	BEF406525-0418-2BE(T)H	9	26	232
18 x 2.5	PUR(NSHTÖU)	19.5	0.68	32	1.2	BEF508032-0418-1AB(T)	4	20	371
				40	1.5	BEF508032-0418-2BD(T)	4	25	406
				13	1.5	BEF264622-0418-2EL(T)	3	17	141
				20	1.6	BEF325524-0418-2DI(T)	6	18	200
24 x 2.5	FLGÖU-J (MTGÖU-J)	27	1.22	29	1.9	BEF406525-0418-2BE(T)H	13	22	259
				36	1.5	BEF508032-0418-2BD(T)	4	25	380
				6	0.9	BEF325524-1824-1MB(T)	8	12	107
				14	1.7	BEF325524-1824-2MB(T)	5	15	240
24 x 2.5	(SMK) (N)SHTÖU-J	27.7	1.32	19	2.2	BEF325524-1824-3MB(T)	4	16	393
				24	1.7	BEF406532-1824-3CC(T)	3	18	455
				33	1.9	BEF508032-1824-2AB(T)	4	20	720
				9	1.0	BEF406525-1824-1BE(T)	3	15	176
24 x 2.5	PUR(NSHTÖU)	24.3	0.82	20	1.8	BEF406525-1824-2BE(T)	3	15	508
				25	1.5	BEF508032-1824-3BE(T)	3	15	615
				35	2.0	BEF508032-1824-2AB(T)	4	20	741
				9	1.1	BEF325524-1824-1MB(T)	5	15	106
30 x 2.5	PUR(NSHTÖU)	27.3	0.97	18	1.9	BEF325524-1824-2MB(T)	4	16	262
				24	2.4	BEF325524-1824-3DI(T)	4	20	295
				34	1.7	BEF508032-1824-2BD(T)	7	22	390
				12	1.2	BEF406525-1830-1CC(T)	12	9	157
36 x 2.5	PUR	25	1.3	21	1.9	BEF406525-1830-2CC(T)	3	18	281
				30	1.7	BEF508032-1830-2BD(T)	12	17	413
				40	2.2	BEF508032-1830-3BD(T)	4	25	577
				6	0.8	BEF325524-1836-1MB(T)	10	10	116
				13	1.5	BEF325524-1836-2MB(T)	5	15	238
4 x 4	NSHTÖU-J	19.1	0.49	19	2.0	BEF325524-1836-3MB(T)	4	16	400
				24	1.6	BEF406532-1836-3CC(T)	3	18	461
				33	1.7	BEF508032-1836-2AB(T)	4	20	728
				9	1.3	BEF224320-4704-1EH(T)	3	13	87
4 x 4	(SMK) (N)SHTÖU-J	17	0.45	16	2.1	BEF224320-4704-2IC(T)H	9	19	108
				22	1.8	BEF325524-0704-2DI(T)	4	20	198
				34	2.0	BEF406525-0704-2BE(T)H	6	29	240
				9	1.7	BEF183616-4704-2EI(T)H	4	16	94
4 x 4	PUR	11.5	0.23	16	2.0	BEF224320-4704-2IC(T)H	6	22	103
				22	1.7	BEF325524-0704-2DI(T)	4	20	201
				34	1.9	BEF406525-0704-2BE(T)H	6	29	243
				5	1.4	BEF152809-4704-2UA	3	11	164
				11	2.0	BEF152813-4704-2QBH	6	30	44
4 x 4	PUR	11.5	0.23	19	1.6	BEF224320-4704-2EH(T)H	6	26	94
				27	2.1	BEF224320-4704-3EH(T)H	9	39	90
				30	1.9	BEF264622-0704-3DH(T)H	12	41	119
				38	1.8	BEF325524-0704-3MB(T)H	17	43	127

Z = no. of conductors nv = required turns for spring preload Lw = winding length Fz = max. cable tension A = Cross-section na = max. working turns Lz = cable layers

Selection Tables for Reels

Application 4: Vertical Lift (Reel on top)

Z x A [mm ²]	Cables Type	ø [mm]	m [kg/m]	Cable Length		Spring Cable Reel Spool - Slip Ring Assembly - Springs	Spring Motor		
				Lw [m]	Lz		nv	na	Fz [N]
4 x 4	PUR(NSHTÖU)	12.7	0.28	5	1.6	BEF152809-4704-1QB	3	15	42
				11	2.9	BEF152809-4704-2QBH	8	28	44
				20	1.8	BEF224320-4704-2EH(T)H	6	26	94
				24	1.7	BEF264622-0704-2DH(T)H	8	27	128
				30	2.0	BEF264622-0704-3DH(T)H	19	34	128
				39	1.7	BEF406525-0704-2CC(T)H	7	35	148
5 x 4	NSHTÖU-J	21.5	0.64	12	1.5	BEF264622-0705-1DH(T)	4	14	122
				16	1.9	BEF264622-0705-2EL(T)	3	17	155
				21	2.0	BEF325524-0705-2DI(T)	6	18	200
				23	2.2	BEF325524-0705-3DI(T)	4	20	297
				26	1.9	BEF406525-0705-2BE(T)H	9	26	223
				30	1.7	BEF406532-0705-2BE(T)H	12	23	256
5 x 4	(SMK) (N)SHTÖU-J	18.4	0.43	40	1.8	BEF508032-0705-2BD(T)	4	25	398
				12	1.7	BEF224320-4705-2IC(T)H	6	22	91
				17	1.8	BEF264622-0705-2DH(T)H	9	26	110
				21	1.7	BEF325524-0705-2DI(T)	4	20	196
				26	1.6	BEF406525-0705-2CC(T)H	20	22	153
				29	1.1	BEF508032-0705-1BD(T)	6	23	180
5 x 4	PUR(NSHTÖU)	13.8	0.32	40	1.5	BEF508032-0705-2BD(T)	4	25	406
				10	1.6	BEF183616-4705-2EI(T)H	4	16	102
				16	1.6	BEF224320-4705-2IC(T)H	6	22	107
				21	2.0	BEF224320-4705-3IC(T)H	9	33	99
				30	1.7	BEF325524-0705-2MB(T)H	12	27	138
				38	1.7	BEF406525-0705-2BE(T)H	6	29	265
4 x 6	NSHTÖU-J	20.7	0.61	12	1.5	BEF264622-0704-1DH(T)	4	14	123
				16	1.9	BEF264622-0704-2EL(T)	3	17	155
				22	1.9	BEF325524-0704-2DI(T)	5	19	200
				28	1.9	BEF406525-0704-2BE(T)H	8	27	227
				40	1.7	BEF508032-0704-2BD(T)	4	25	400
				13	1.8	BEF224320-4704-2IC(T)H	10	18	104
4 x 6	(SMK) (N)SHTÖU-J	18.4	0.57	15	1.6	BEF264622-0704-2EL(T)	3	17	153
				22	1.8	BEF325524-0704-2DI(T)	4	20	199
				28	1.7	BEF406525-0704-2BE(T)H	6	29	219
				40	1.5	BEF508032-0704-2BD(T)	4	25	406
				6	1.1	BEF183616-4704-1FD(T)	3	11	63
4 x 6	PUR(NSHTÖU)	14	0.37	12	1.8	BEF183616-4704-2FD(T)H	9	19	66
				19	1.9	BEF224320-4704-3IC(T)H	10	32	97
				23	1.8	BEF264622-0704-2DH(T)H	9	25	129
				32	1.5	BEF406525-0704-2CC(T)H	18	24	161
				40	1.5	BEF406532-0704-3BE(T)H	9	44	219
				6	1.4	BEF183616-4705-1FD(T)	4	10	62
5 x 6	(SMK) (N)SHTÖU-J	20	0.69	11	1.6	BEF224320-4705-2IC(T)H	13	15	104
				18	1.6	BEF325524-0705-2DI(T)	5	19	187
				23	2.0	BEF325524-0705-3DI(T)	4	20	301
				32	1.3	BEF508032-0705-1AB(T)	4	20	368
				39	1.6	BEF508032-0705-2BD(T)	4	25	397
				5	1.6	BEF152809-4704-1QB	3	15	42

Z = no. of conductors nv = required turns for spring preload Lw = winding length Fz = max. cable tension A = Cross-section na = max. working turns Lz = cable layers

Selection Tables for Reels

Application 4: Vertical Lift (Reel on top)

Z x A [mm ²]	Cables Type	ø [mm]	m [kg/m]	Cable Length		Spring Cable Reel Spool - Slip Ring Assembly - Springs	Spring Motor		
				Lw [m]	Lz		nv	na	Fz [N]
5 x 6	PUR(NSHTÖU)	15.3	0.43	10	1.7	BEF183616-4705-2EI(T)H	4	16	100
				14	1.5	BEF224320-4705-2IC(T)H	6	22	100
				19	1.6	BEF264622-0705-2DH(T)H	12	23	123
				26	1.4	BEF406525-0705-2CC(T)H	19	23	152
				34	1.7	BEF406525-0705-2BE(T)H	6	29	246
				40	1.6	BEF406532-0705-3BE(T)H	12	41	228
4 x 10	NSHTÖU-J	25	0.94	8	1.0	BEF325524-1504-1MB(T)	7	13	110
				18	1.9	BEF325524-1504-2MB(T)	4	16	261
				24	1.9	BEF406525-1504-2CC(T)	3	18	304
				30	1.6	BEF508032-1504-3CC(T)	4	17	375
				41	2.1	BEF508032-1504-3BD(T)	4	25	593
4 x 10	(SMK) (N)SHTÖU-J	22.6	0.9	8	0.9	BEF325524-1504-1MB(T)	6	14	108
				18	1.8	BEF325524-1504-2MB(T)	4	16	265
				24	1.8	BEF406525-1504-2CC(T)	3	18	309
				30	1.4	BEF508032-1504-3CC(T)	3	18	372
4 x 10	PUR	15.5	0.5	11	1.1	BEF264622-1504-1EL(T)	7	13	79
				15	1.3	BEF264622-1504-2EL(T)	3	17	158
				21	1.4	BEF325524-1504-2DI(T)	4	20	200
				29	1.5	BEF406525-1504-2BE(T)H	6	29	227
				39	1.6	BEF406532-1504-3BE(T)H	21	32	258
4 x 10	PUR(NSHTÖU)	17.9	0.61	12	1.3	BEF264622-1504-1DH(T)	4	14	125
				15	1.5	BEF264622-1504-2EL(T)	3	17	155
				22	1.7	BEF325524-1504-2DI(T)	4	20	200
				29	1.8	BEF406525-1504-2BE(T)H	8	27	234
5 x 10	(SMK) (N)SHTÖU-J	24.4	1.08	39	1.5	BEF508032-1504-2BD(T)	4	25	400
				8	1.0	BEF325524-1505-1MB(T)	11	9	127
				17	1.8	BEF325524-1505-2MB(T)	5	15	263
				24	1.5	BEF406532-1505-3CC(T)	3	18	464
				32	1.6	BEF508032-1505-2AB(T)	4	20	720
5 x 10	PUR(NSHTÖU)	19.5	0.7	40	1.9	BEF508032-1505-3BD(T)	5	24	604
				11	1.3	BEF264622-1505-1DH(T)	4	14	120
				16	1.7	BEF264622-1505-2EL(T)	3	17	158
				22	1.8	BEF325524-1505-3DI(T)	4	20	297
4 x 16	NSHTÖU-J	29	1.32	28	1.9	BEF406525-1505-2BE(T)H	14	21	260
				39	1.6	BEF508032-1505-2BD(T)	4	25	397
				12	1.4	BEF406525-1604-1BE(T)	4	14	207
4 x 16	(SMK) (N)SHTÖU-J	25.2	1.24	21	2.1	BEF406525-1604-2BE(T)	3	15	515
				25	1.5	BEF508032-1604-3BE(T)	3	15	612
				33	1.9	BEF508032-1604-1AB(T)	4	20	715
				12	1.2	BEF406525-1604-1BE(T)	3	15	200
4 x 16	PUR	19	0.8	20	1.8	BEF406525-1604-2BE(T)	3	15	514
				24	1.3	BEF508032-1604-2BE(T)	3	15	405
				33	1.7	BEF508032-1604-2AB(T)	4	20	728
				12	0.9	BEF406525-1604-1CC(T)	6	15	130
				19	1.2	BEF406525-1604-1BE(T)	3	15	261
4 x 16	PUR(NSHTÖU)	22.3	0.92	24	1.5	BEF406525-1604-2CC(T)	3	18	317
				27	1.1	BEF508032-1604-1AB(T)	4	20	337
				40	1.6	BEF508032-1604-3BD(T)	4	25	606
				12	1.0	BEF406525-1604-1CC(T)	10	11	148
4 x 16	PUR(NSHTÖU)	22.3	0.92	19	1.4	BEF406525-1604-1BE(T)	3	15	256
				24	1.8	BEF406525-1604-2CC(T)	3	18	310
				27	1.3	BEF508032-1604-1AB(T)	6	18	355
				40	1.8	BEF508032-1604-3BD(T)	4	25	595

Z = no. of conductors nv = required turns for spring preload Lw = winding length Fz = max. cable tension A = Cross-section na = max. working turns Lz = cable layers

Selection Tables for Reels

Application 4: Vertical Lift (Reel on top)

Z x A [mm ²]	Cables Type	ø [mm]	m [kg/m]	Cable Length		Spring Cable Reel Spool - Slip Ring Assembly - Springs	Spring Motor		
				Lw [m]	Lz		nv	na	Fz [N]
5 x 16	(SMK) (N)SHTÖU-J	27.6	1.5	12	1.2	BEF406525-1605-1BE(T)	7	11	241
				22	1.6	BEF406532-1605-3CC(T)	3	18	434
				33	1.9	BEF508032-1605-2AB(T)	4	20	718
5 x 16	PUR(NSHTÖU)	24.3	1.07	12	1.1	BEF406525-1605-1BE(T)	3	15	201
				19	1.6	BEF406525-1605-2CC(T)	3	18	273
				24	1.5	BEF406532-1605-3CC(T)	3	18	464
				27	1.4	BEF508032-1605-2BD(T)	13	16	413
				40	1.9	BEF508032-1605-3BD(T)	5	24	604
4 x 25	(SMK) (N)SHTÖU-J	30	1.85	12	0.9	BEF508032-1904-2BE(T)	4	14	302
				20	1.4	BEF508032-1904-3BE(T)	3	15	540
				33	2.0	BEF508032-1904-3AB(T)	4	20	1062
4 x 25	PUR(NSHTÖU)	25.8	1.27	12	1.2	BEF406525-1904-1BE(T)	3	15	199
				18	1.7	BEF406525-1904-2CC(T)	7	14	303
				23	1.5	BEF406532-1904-3CC(T)	3	18	450
				35	1.8	BEF508032-1904-2AB(T)	4	20	750
4 x 35	PUR(NSHTÖU)	28.3	1.72	11	1.3	BEF406525-1904-1BE(T)	9	9	253
				20	2.0	BEF406525-1904-2BE(T)	3	15	503
				30	1.7	BEF508032-1904-2AB(T)	6	18	726
19 x 2.5 + 5 x 1 (C)	(SMK) (N)SHTÖU-J	27.7	1.29	7	0.8	BEF406525-1824-1CC(T)	9	12	123
				12	1.2	BEF406525-1824-1BE(T)	4	14	209
				17	1.6	BEF406525-1824-2CC(T)	7	14	294
				24	1.7	BEF406532-1824-3CC(T)	3	18	453
				33	1.9	BEF508032-1824-2AB(T)	4	20	718
				8	1.0	BEF325524-1830-1MB(T)	8	12	115
26 x 2.5 + 4 x 2.5 (C)	PUR	24.5	1.22	14	1.6	BEF325524-1830-2MB(T)	4	16	237
				20	2.1	BEF325524-1830-3D(T)	7	17	296
				24	1.9	BEF406525-1830-2CC(T)	4	17	315
				33	1.6	BEF508032-1830-2AB(T)	4	20	732
				7	0.7	BEF406525-1904-1CC(T)	4	17	101
3 x 25 + 3G6	PUR	21.5	1.04	12	1.0	BEF406525-1904-1BE(T)	3	15	204
				20	1.2	BEF406532-1904-2CC(T)	3	18	286
				24	1.4	BEF406532-1904-3CC(T)	3	18	471
				33	1.5	BEF508032-1904-2AB(T)	4	20	742
				9	1.1	BEF406525-1904-1BE(T)	11	7	257
3 x 35 + 3 x 16/3	(SMK) (N)SHTÖU-J	30	2.16	14	1.5	BEF406525-1904-2BE(T)	3	15	418
				20	1.6	BEF406532-1904-3BE(T)	3	15	760
				33	2.0	BEF508032-1904-3AB(T)	4	20	1062
3 x 35 + 3G6	PUR	25	1.41	9	0.9	BEF406525-1904-1BE(T)	3	15	178
				15	1.3	BEF406525-1904-2CC(T)	7	14	285
				20	1.6	BEF406525-1904-2BE(T)	3	15	518
				33	1.7	BEF508032-1904-2AB(T)	4	20	728

Z = no. of conductors nv = required turns for spring preload Lw = winding length Fz = max. cable tension A = Cross-section na = max. working turns Lz = cable layers

The reel types presented in these tables have been categorised according to their maximum spring forces, maximum winding capabilities and maximum permissible cable tension. The part numbers all refer to the standard reel which unwinds counterclockwise.

Springs and Slip Ring Assemblies

Spring Motors and Spring Forces

Reel Type	Spring Motor	nBlock	Spring Data		Spring Force		
			nv	nr	Fe [N]	Fa [N]	Fz [N]
BEF152813	1UA(T)	15	3	1	52	14	95
BEF152815	3QB(T)H	57	9	3	67	29	115
BEF183616	1EI(T)	11	2	1	98	44	107
	2EI(T)H	22	4	2	98	40	107
	2FD(T)H	30	6	2	58	27	69
BEF224320	1EH(T)	17	3	1	84	38	95
	1IC(T)	15	3	1	101	47	111
	2EH(T)H	34	6	2	84	34	95
	2IC(T)H	30	6	2	101	43	111
	3EH(T)H	51	9	3	84	31	95
BEF264622	1DH(T)	18,5	4	1	107	60	129
	2DH(T)H	37	8	2	107	57	129
	2EL(T)	21	3	1	144	53	161
	2EL(T)H	42	6	2	72	24	81
	3DH(T)H	55,5	12	3	107	52	129
BEF325524	3EL(T)H	63	9	3	72	22	81
	1MB(T)	22	4	2	121	62	138
	2DI(T)	26	4	2	173	90	204
	2DI(T)H	52	8	4	86	41	102
	2MB(T)	22	4	2	243	124	276
	2MB(T)H	44	8	4	121	58	138
	3DI(T)	26	4	2	259	135	307
	3DI(T)H	78	12	6	86	38	102
BEF406525	3MB(T)	22	4	2	364	186	413
	3MB(T)H	66	12	6	121	54	138
	1BE(T)	18,5	3	1	216	71	254
	1CC(T)	21	3	1	151	52	177
	2BE(T)	18,5	3	1	432	142	507
BEF406532	2BE(T)H	37	6	2	216	72	254
	2CC(T)	21	3	1	302	105	355
	2CC(T)H	42	6	2	151	49	177
	2BE(T)H	37	6	2	216	74	254
BEF508032	2CC(T)H	42	6	2	151	51	177
	3BE(T)H	55,5	9	3	216	69	254
	3CC(T)	21	3	1	454	160	532
	3CC(T)H	63	9	3	151	48	177
	1AB(T)	23,5	4	1	277	96	326
BEF508032	1BE(T)	18,5	3	1	171	57	200
	2AB(T)	23,5	4	1	543	169	637
	2AB(T)H	47	8	2	277	96	326
	2BD(T)	28	4	1	314	99	369
	2BD(T)H	56	8	2	161	54	189
	2BE(T)	18,5	3	1	334	103	392
	2BE(T)H	37	6	2	171	59	200
	2CC(T)	21	3	1	239	84	280
	3AB(T)	23,5	4	1	832	287	977
	3BD(T)	28	4	1	482	171	566
	3BE(T)	18,5	3	1	512	172	601
3BE(T)H	55,5	9	3	171	56	200	
3CC(T)	21	3	1	358	127	421	
3CC(T)H	63	9	3	119	39	140	

Slip Ring Assemblies

Type	Arrangement [V~]	Terminal Connect.
0403	2 x 25 A+SL 415V	yes
0404	3 x 25 A+SL 415V	yes
0405	4 x 25 A+SL 415V	yes
0407	6 x 25 A+SL 415V	yes
0412	11 x 25 A+SL 415V	yes
0418	17 x 25 A+SL 415V	yes
0704	3 x 47 A+SL 660V	yes
0705	4 x 47 A+SL 660V	yes
1304	3 x 50 A+SL 500V	-
1305	4 x 50 A+SL 500V	-
1504	3 x 90 A+SL 500V	-
1604	3 x 100 A+SL 660V	-
1824	23 x 25 A+SL 500V	yes
1830	29 x 25 A+SL 500V	yes
1904	3 x 150 A+SL 660V	-
4503	2 x 25 A+SL 415V	yes
4504	3 x 25 A+SL 415V	yes
4505	4 x 25 A+SL 415V	yes
4507	6 x 25 A+SL 415V	yes
4512	11 x 25 A+SL 415V	yes
4704	3 x 47 A+SL 660V	yes

Terminology, Spring Data:

- **nBlock:** Maximum number of spring turns
- **nv:** Required number of pre-turns for pre-loading the spring motor
- **nr:** Number of remaining spare windings when maximum winding length of cable is achieved

Terminology, Spring Forces:

- **Fe:** Retarding spring motor force if cable is fully unwound (during unwinding)
- **Fa:** Remaining spring motor force if cable is fully wound-up (during winding)
- **Fz:** Maximum cable tension when cable is fully unwound from reel

All stated forces refer to the specific drum diameter of reels noted at minimum pre-turns.

Dimensional Details

Spring Cable Reels BEF 150

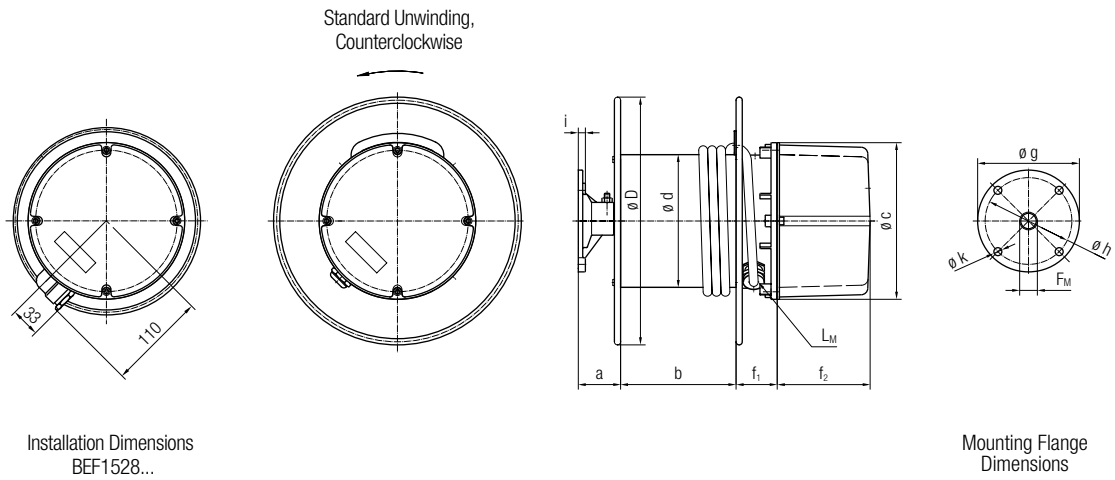

Overall Cable Reel Dimensions

Type	Reel			Mounting Flange					
	$\varnothing d$ [mm]	$\varnothing D$ [mm]	b [mm]	a [mm]	$\varnothing g$ [mm]	$\varnothing h$ [mm]	i [mm]	$\varnothing k$ [mm]	F_M [mm]
BEF 152809			95						
BEF 152813	150	280	130	48	115	98	8	9	M20 x 1.5
BEF 152815			150						

Types and Dimensions of the Slip Ring Assemblies

Slip Ring Assembly	I [A]	U [V]	$\varnothing c$ [mm]	L_M	f_1 [mm]	Max. Poles / f_2	
45/1		415				5 / 105	12 / 215
45/2	25		182	M20 x 1.5	47	3 / 105	7 / 215
45/3	47	1000				-	5 / 215

Dimensional Details

Spring Cable Reels BEF 180 to 500

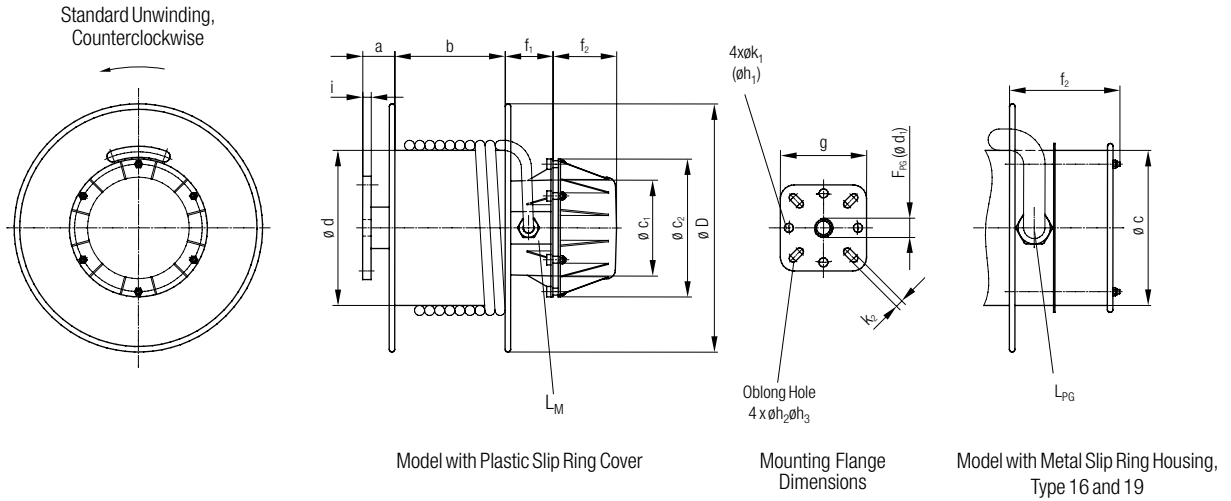

Overall Cable Reel Dimensions

Type	Reel			Mounting Flange								
	ø d [mm]	ø D [mm]	b [mm]	a [mm]	g [mm]	ø h ₁ [mm]	ø h ₂ [mm]	ø h ₃ [mm]	i [mm]	ø k ₁ [mm]	ø k ₂ [mm]	F _{PG} ø d ₁ [mm]
BEF 183616	185	360	160	46.5	125	100	98	125	12.3	13	11	21 (27)
BEF 224320	225	430	200									
BEF 264622	265	460	220									
BEF 325524	325	550	235	66	160	-	140	180	20	-	17	36 (45)
BEF 406525	400	650	252									
BEF 406532	400	650	320									
BEF 508032	510	800	320									

Types and Dimensions of the Slip Ring Assemblies

Reel Type	Type	Slip Ring Assembly			f ₁ [mm]	L _M	ø C [mm]	ø c ₁ [mm]	ø c ₂ [mm]	Cover				Mat. ¹⁾	
		Max. Poles	I [A]	U [V]						Max. Poles (with terminal board) / f ₂ [f ₂ = mm]					
18....	45	12	25	415	69	M25x1.5 / M32x1.5	-	140	200	5/90	9/150	12/190	-	KS	
22....	45	12	25	415	69	M25x1.5 / M32x1.5	-	140	200	5/90	9/150	12/190	-		
	46	7	25	660						3/90	5/150	6/190	7/280		
	47	4	47	660						4/150	-	-	-		
26....32	4	18	25	415	69	M25x1.5 / M32x1.5	-	140	200	5/90	9/150	12/190	18/280		
	5	7	25	660						3/90	5/150	6/190	7/280		
	7	5	47	660						4/150	5/190	-	-		
	13	5	50	500						4/125	7/190	11/280	-		
	15	5	90	500	3/125	6/190	9/280	-							
	18	36	25	500	69	-	M25x1.5 / M32x1.5	-	140	200	18/190	24/280	-		-
					114						M25x1.5 / M40x1.5	36/280	-		-
40....50	4	18	25	415	69	M25x1.5 / M32x1.5	-	140	200	4/90	8/150	11/190	18/280		
	5	7	25	660						3/90	5/150	6/190	7/280		
	7	5	47	660						3/150	4/190	5/280	-		
	13	5	50	500						4/125	7/190	11/280	-		
	15	5	90	500	3/125	6/190	9/280	-							
	18	36	25	500	69	-	M25x1.5 / M32x1.5	-	140	200	18/190	24/280	-		-
					114						M25x1.5 / M40x1.5	36/280	-		-
	16	5	100	660	-	-	M50x1.5	400	-	-	4/260 ²⁾	5/350 ²⁾	-		-
19	150		-								-	-	-		BI

Slip Ring Assemblies are rated at 100% Duty Cycle

1) KS = Plastic; BI = Sheet Metal

2) Number of poles without terminal board

Accessories

Cable Grips (Z100)

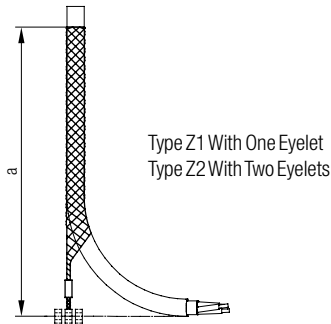

Type	Order No.	Cable Diameter [mm]	Perm. Load [kg]	a [mm]	Eyelet ϕ [mm]	Dia. No.	Weight [kg]
Z1-10	1036968	10	200	650	9 - 16	1	0.05
Z1-15	1036969	10 - 15	250	700	9 - 16	1	0.08
Z1-20	1036970	15 - 20	400	700	9 - 16	1	0.09
Z1-30	93702	20 - 30	500	700	16 - 20	1	0.10
Z1-40	1036972	30 - 40	750	700	16 - 20	1	0.15
Z1-50	1036973	40 - 50	1300	700	20 - 24	1	0.20
Z1-60	1036974	50 - 60	1500	700	20 - 24	1	0.30
Z2-27	1036975	21 - 27	500	700	16 - 18	2	0.16
Z2-35	1036976	28 - 35	750	700	14 - 20	2	0.20
Z2-45	1036977	36 - 45	1300	700	14 - 20	2	0.20
Z2-55	1036978	46 - 55	1500	700	17 - 20	2	0.30

The cable grips are made of galvanised steel wire for the distribution of dynamic stresses over a sufficient jacket surface area to inhibit cable damage.

Cable Collars (Z105)

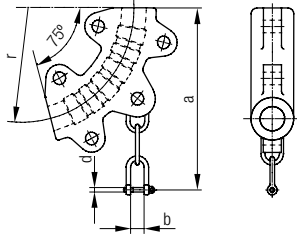

Type	Order No.	Cable Diameter [mm]	r [mm]	a [mm]	d [mm]	b [mm]	Weight [kg]
LS 1	1012370	- 21.5	100	205	10	14	1.6
LS 2	1012371	> 21.5 - 28.0	130	225			2.8
LS 3	1012372	> 28.0 - 36.5	170	265	12	17	3.5
LS 4	1012373	> 36.5 - 48.0	220	300			5.5

Deflection Pulley < 1kV (Z410)

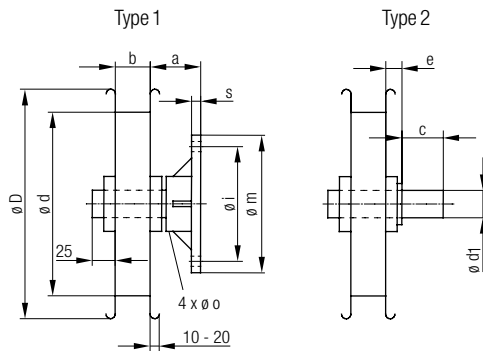

Type	Order No.	
	Type 1	Type 2
UR-200	1020400	1036987
UR-260	1020883	1036988
UR-385	1029377	1029911
UR-510	1029912	1029913

Type	ϕd [mm]	ϕD [mm]	a [mm]	b [mm]	c [mm]	e [mm]	ϕd_1 [mm]	ϕi [mm]	ϕm [mm]	ϕo [mm]	s [mm]	Weight [kg]
UR-200	200	250	55	38	31	14	30 ¹⁾	125	150	11	10	3
UR-260	260	300	55									4
UR-385	385	450	76.5	45	43	19	45 ²⁾	140	175	17	16	15
UR-510	510	580	76.5									19

Tolerance: 1) 30 ± 0.30
2) 45 ± 0.45

Accessories

Rubber End Stops (Z475) for Cables, Hoses and Wire Ropes

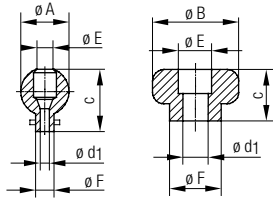

Type	Order No.	Cable or Wire Diameter- \varnothing		Dimensions [mm]					
		from [mm]	to [mm]	$\varnothing A$	$\varnothing B$	C	$\varnothing d_1$	$\varnothing E$	$\varnothing F$
Limit Stop G1	35485	4	6	42	-	50	6	18	13
Limit Stop G2	35486	6	8	42	-	50	8	20	16
Limit Stop G3	35487	10	14	49	-	50	14	14	22
Limit Stop G4	35488	12	15	49	-	50	15	19	22

Support Rollers (Z480)

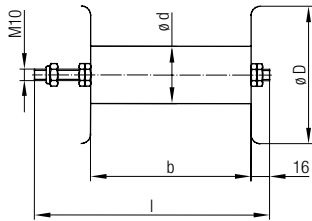

Type	Order No.	Dimensions [mm]				Weight [kg]
		$\varnothing d$	$\varnothing D$	b	l	
50 x 140	1145960			140	205	0.55
50 x 190	1145961	50	120	190	255	0.62
50 x 290	1145962			290	355	0.77

Roller: plastic
Flanges and hardware: galvanized steel

Cable roller guides are of a synthetic insulating material with maintenance free bearings. The roll body is insulated from the axle.
Roller guides in longer lengths and diameters, as well as in heavy-duty design, with and without flanges are available.

Roller Nozzles (Z600)

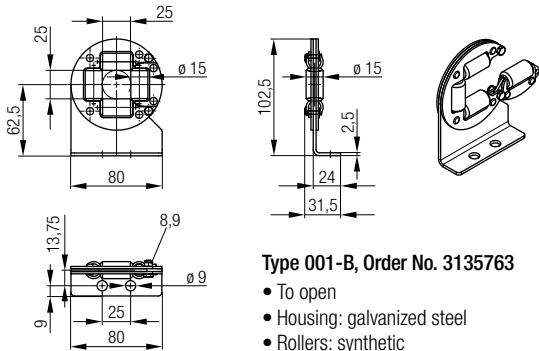

Type 001-B, Order No. 3135763

- To open
- Housing: galvanized steel
- Rollers: synthetic
- Temperature range: -40° C to +60° C

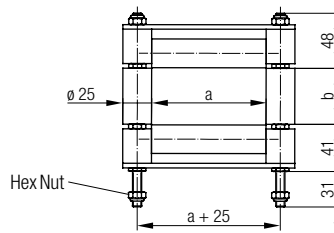
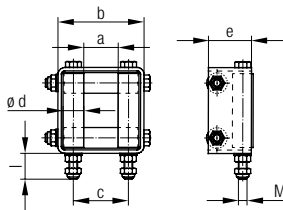

Type	Order No.	Dimensions [mm]						
		a	b	c	$\varnothing d$	e	l	M
003	92027	10	40	22				
004	92028	20	50	32	12	25	15	5
005	1018357	32	70	47	15	29	20	6

- Housing: galvanized steel
- Rollers: synthetic
- Temperature range: -40° C to +60° C

Type	Order No.	Dimensions [mm]	
		a	b
002-1305	1018358	130	45
002-2205	1036348	220	45
002-0606	1036351	60	60

Special Dimensions On Request

- Brackets and screws: galvanized steel
- Rollers and pieces: synthetic
- Temperature range: -40° C to +60° C
- Measurements a + b can be adjusted to your needs.

Roller guides have various applications including telescopic crane booms as well as manual hose and cable reels.

Accessories

Easy Mounting Roller Guides Open (Z610)

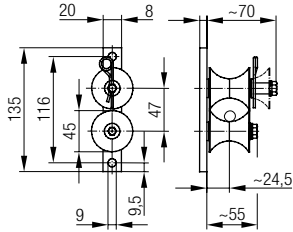

Type A3-720, Order No. 1036413

For max. cable diameter of: 12 mm

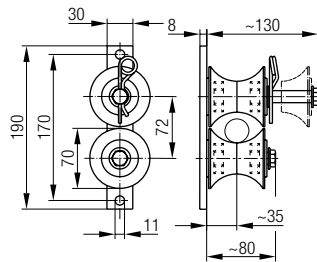

Type A3-702, Order No. 1036412

Maximum cable diameter of 28 mm with plug can be added to this guide roller later on without any problems by removing retaining clip and sliding off roller.

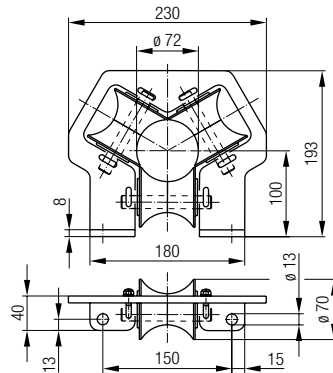

Type A4-774, Order No. 1042940

Round opening guide rollers with sealed bearings and opening diameter of 72 mm. The lower roller can be easily removed when fitting the cable.

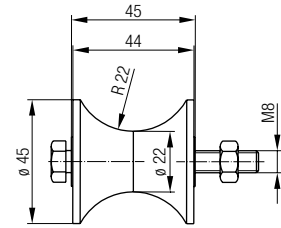

Type 4-R 004-0033, Order No. 1018490

Individual synthetic roller (Macrolon) with distance-tube and M8 x 70 screw, DIN 931

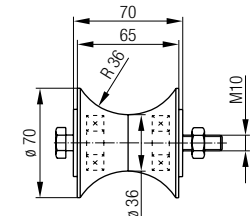

Type A4-859, Order No. 92037

Individual synthetic roller (Macrolon) with complete bearing and M10 x 100 screw, DIN 931

Terminal Box Mounting Flange (Z630)

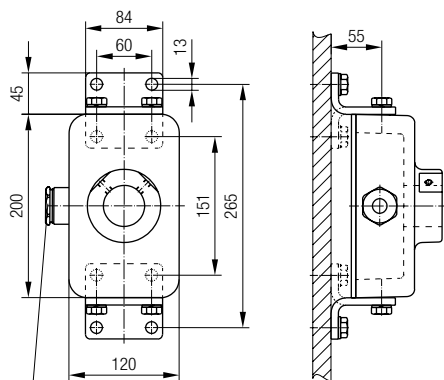

Pg 29

Terminal box with side entry cable connection.

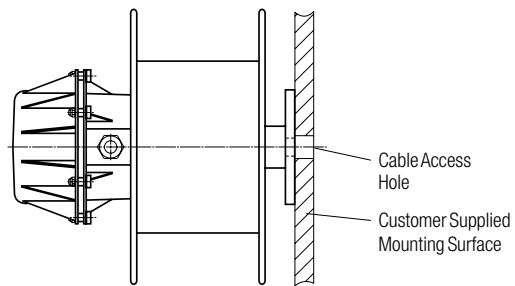

Installation arrangement with standard flange.

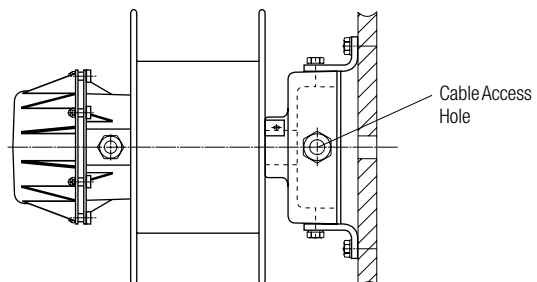

Installation arrangement with terminal box mounting flange.

Accessories

Mounting Stands (Z650)

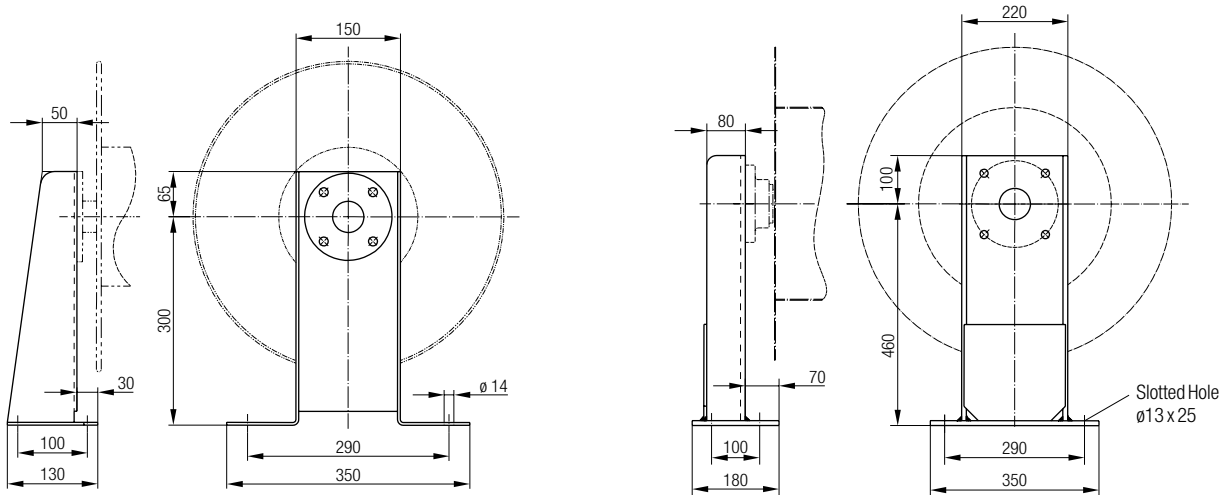

Type 300, Order No. 36945

Maximum 550 mm round cable diameter
for reel types
BEF15.., BEF 18.., BEF 22.., BEF 26.., BEF 32..

Type 450, Order No. 1153243

Maximum 800 mm round cable diameter
for reel types
BEF 40.., BEF 50..

Heater Units (Z700)

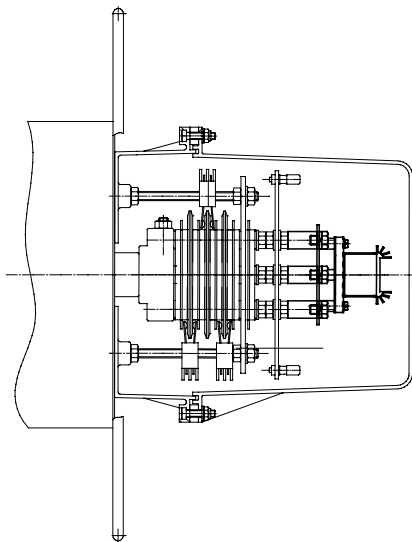

Thermostatically controlled resistance heater with automatic shut-off.
Suitable for tropical locations.

- Shut-off point approx. +50° C (within slip ring housing)
- Turn-on point at approx. +25° C
- Capacity: 20 Watt, for slip ring cover volumes of 10 to 30 litres
- Voltage: Standard 220 to 240 V AC
- All units available in DC (=)

Limit-Switches (Z720)

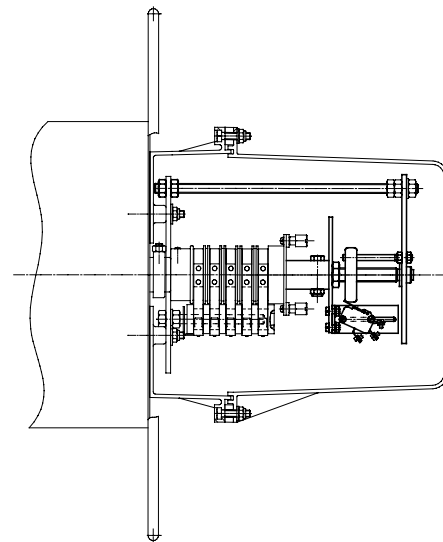

- Electrical connection: UP to maximum 500 V, 50 Hz, 10 A
- Switch range: One meter to maximum cable length shown in the selection tables
- Service life: 10,000,000 switch cycles
- Also available with two limit switches

Note:

The dimension (f₂) in the dimension drawings (pages 34 and 35) may increase by +200 mm depending on the equipped slip rings.

Accessories

Locking Devices for Manually Operated Spring Cable Reels (Z900)

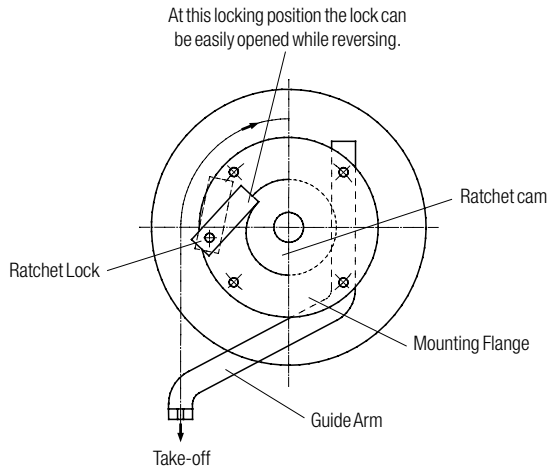

Free-Falling Ratchet Device

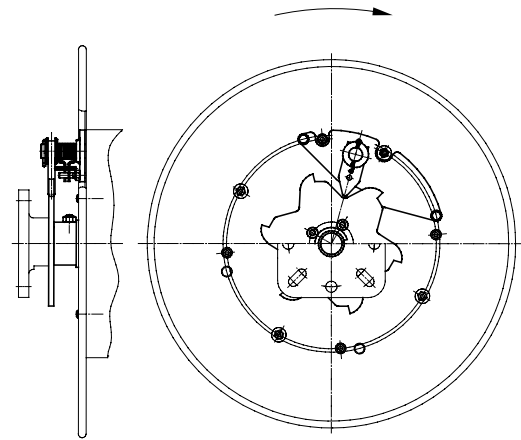

Spring operated Ratchet Device

Type 150

For reel type BEF15...
(One locking position per reel rotation)

Reel Type	Order No.	Locking Positions per Rotation
BEF 18...	1149737	4
BEF 22...		
BEF 26...	1149739	6
BEF 32...		
BEF 40...	1152795	6
BEF 50...	1153466	6

Rigid Guide Arm (Z910)

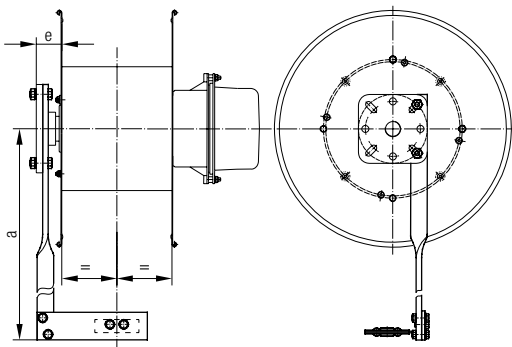

Reel Type	a [mm]	e ¹⁾ [mm]	e ²⁾ [mm]
BEF 15...	410	48	58
BEF 18...	800	47	80
BEF 22...			
BEF 26...	1000	64	112
BEF 32...			
BEF 40...	500 ³⁾	64	112
BEF 50...			

1) = With Ratchet

2) = Without Ratchet

3) 1000 mm with type BEF406525-... and roller guide 005

Swivelling Guide Arm (Z920)

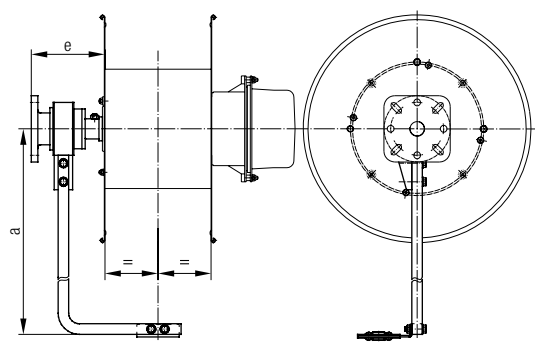

Reel Type	a [mm]	e ¹⁾ [mm]	e ²⁾ [mm]
BEF 15...	428	85	85
BEF 18...	800	109	141
BEF 22...			
BEF 26...	1000	109	139
BEF 32...			
BEF 40...	500 ³⁾	131,5	180
BEF 50...			

1) = With Ratchet

2) = Without Ratchet

3) 1000 mm with type BEF406525-... and roller guide 005

Accessories

Swivelling Console with Slip Ring Assembly and Rigid or Swivelling Guide Arm (Z950)

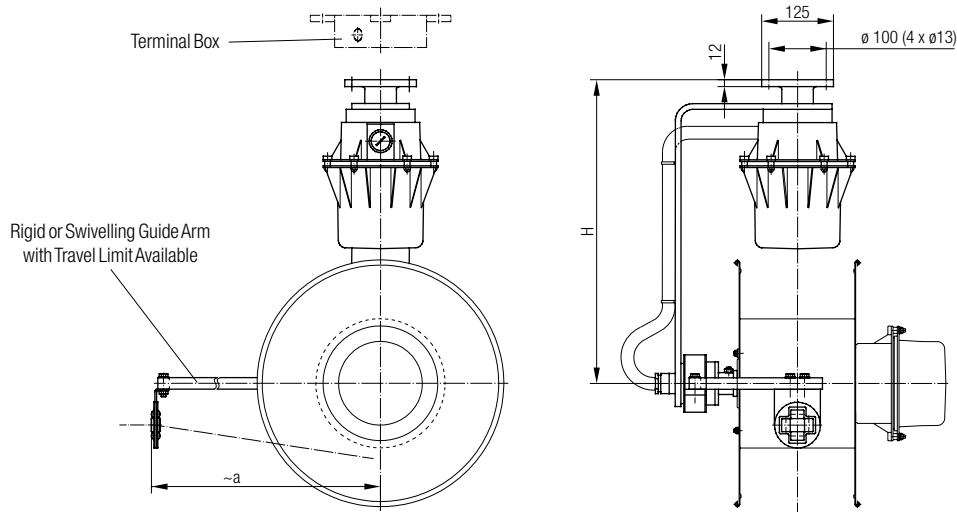

Reel Type	H [mm]	a [mm]	
		Rigid	Swivelling
BEF 15...	Dimensions available upon request. The dimensions vary depending on cable and Slip Ring Assembly.	410	428
BEF 18...		800	800
BEF 22...		1000	1000
BEF 26...		500 ¹⁾	500 ¹⁾
BEF 32...			
BEF 40...			
BEF 50...			

1) 1000 mm with type BEF406525-... and roller guide 005

Swivelling Console with Rigid or Swivelling Guide Arm (Z960 - Swivel Range 350° max.)

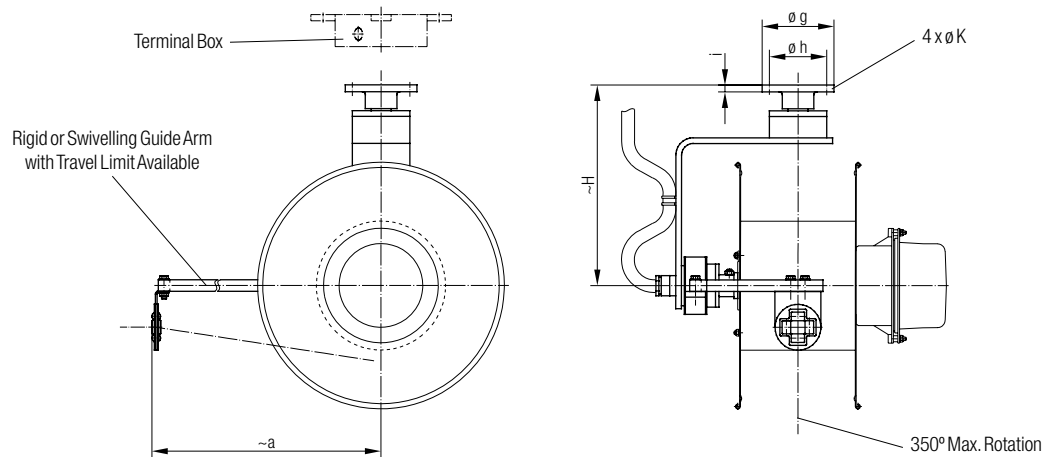

Reel Type	ø g [mm]	ø h [mm]	l [mm]	ø k [mm]	H [mm]	a [mm]	
						Rigid	Swivelling
BEF 15...	150	125	12	11,5	260	410	428
BEF 18...					800	800	
BEF 22...					350	1000	1000
BEF 26...					500	500 ¹⁾	500 ¹⁾
BEF 32...					580		
BEF 40...							
BEF 50...	240	180	20	17			

1) 1000 mm with type BEF406525-... and roller guide 005

Application - Please mark -

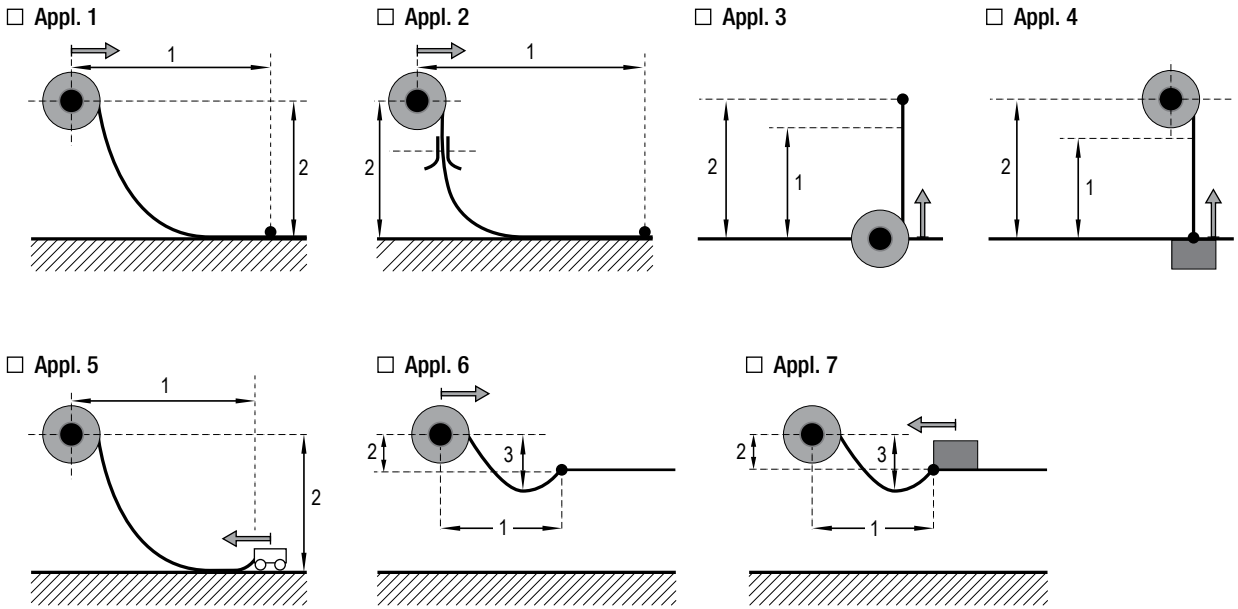

Application Data

- Speed _____ [m/min]
- Acceleration _____ [m/s²]
- Run-Up time _____ [s]
- Operating Voltage _____ [V]
- Frequency _____ [Hz]
- Feed-in Center feed End feed
- Winding length / lift [1] _____ [m]
- Mounting height of the cable reel [2] _____ [m]
- Max. cable sag [3] _____ [m]

Cable Data

- Type _____
- Number of Cores x nominal cross section _____

Data for Cable Determination

- Power _____ [kW]
- Voltage _____ [V]
- Amperage _____ [A]
- PE yes no
- N yes no
- Number of Cores _____
- Number of Screened Cores _____
- Cores for Bus System:
- Type _____
- Transmission rate _____
- Number of pairs _____

Operating Conditions

- Site indoors outdoors port tropics subtropics
- Degree of pollution little medium strong
- Aggressive media yes no
- Type _____
- Concentration _____
- Ambient Temperature min _____ [°C] max _____ [°C]
- Humidity _____ [%]
- Protection type IP _____

Accessories

- Tension Relief:
- Cable mesh grip
- Mounting stand
- Guide arm
- Ratchet device
- Cable Guide:
- Cable guide
- Roller guide
- Cable guide roller
- Cable center feed point

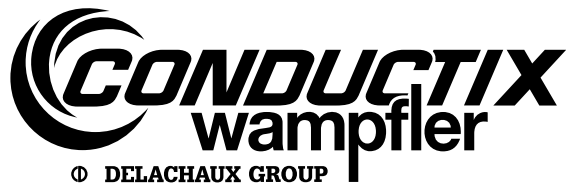

Required Documentation (hardcopies / digital)

_____	_____	_____
_____	_____	_____
_____	_____	_____
_____	_____	_____
_____	_____	_____
_____	_____	_____

Special packaging

_____	_____	_____
_____	_____	_____
_____	_____	_____
_____	_____	_____
_____	_____	_____
_____	_____	_____

Further Comments / Remarks

_____	_____	_____
_____	_____	_____
_____	_____	_____
_____	_____	_____
_____	_____	_____
_____	_____	_____

Customer Data

Company: _____ Customer-No.: _____
FAO: _____
Address: _____

Phone: _____ Fax: _____
E-Mail: _____

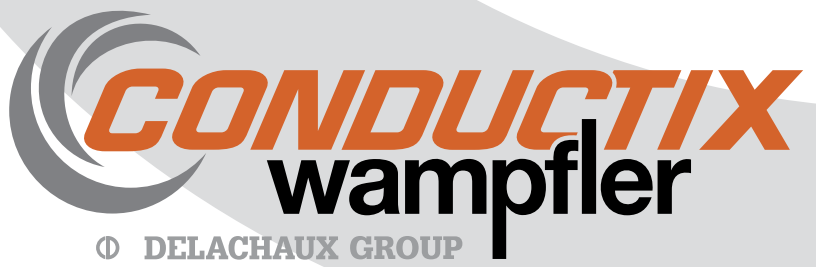

DELACHAUX GROUP